

ultraframe

Classic



It is Ultraframe's policy to continually seek to improve its products, processes and services, and we reserve the right to change specifications without prior notice. Ultraframe is a trading name of Ultraframe (UK) Limited.

Buy direct or from your nearest Ultraframe fabricator/distributor:



Ultraframe (UK) Ltd
Salthill Road,
Clitheroe,
Lancashire, BB7 1PE

Fabricator First Team tel : 08704 141006
Installer First Team tel : 08704 141002

www.ultraframe.com

FORM001 IW 1000 0107



world class conservatory systems

Formulae Guide

Version: 3.0
Jan 07

CONTENTS

TRIGONOMETRYPAGE 2
 EXAMPLE: BASICPAGE 3
 EXAMPLE: PYTHAGORAS THEOREMPAGE 4
 FIND DIMENSION XPAGE 5
 HOW TO CALCULATE: INTRODUCTIONPAGE 6
 HOW TO CALCULATE: EQUAL INTERNAL ANGLESPAGE 7
 HOW TO CALCULATE: EQUAL FACET SIZESPAGE 8
 HOW TO CALCULATE: BAY PROJECTIONPAGE 9
 HOW TO CALCULATE: A LEAN-TO PITCHPAGE 10
 HOW TO CALCULATE: A LEAN-TO PITCH OFF A VICTORIANPAGE 11
 1 UP 4 DOWN: MAIN RIDGE BODY RULESPAGE 12
 TAPERING EAVES BEAM OR BOX GUTTERPAGE 13
 HOW TO CALCULATE: A DROP VALLEY PITCHPAGE 14
 HOW TO CALCULATE: P SHAPE HALF RIDGE LENGTHPAGE 15
 HOW TO CALCULATE: WIRE FRAME GLAZING BAR LENGTHPAGE 16
 HOW TO CALCULATE: VENTILATED WALLPLATE HEIGHTSPAGE 17
 HOW TO CALCULATE: PWP & PWL WALLPLATE HEIGHTSPAGE 18
 HOW TO CALCULATE: RIDGE LENGTHSPAGE 19
 HOW TO CALCULATE: PITCH & HEIGHTPAGE 20
 HOW TO CALCULATE: EXTERNAL BASE & INTERNAL FRAMEPAGE 21
 HOW TO CALCULATE: TOTAL HEIGHT OF ROOF-FOR LEADPAGE 22
 HOW TO CALCULATE: THE ROOF SIZE (PROJECTION)PAGE 23
 HOW TO CALCULATE: A DOOR OPENING ON A 3 & 5 FACETPAGE 24
 HOW TO CALCULATE: THE TOTAL ROOF VOLUMEPAGE 25

TRIGONOMETRY

REMEMBER SOH - CAH - TOA FROM SCHOOL
 WE USE THE ABOVE FOR CALCULATING CONSERVATORY
 ROOFS. BELOW WE HAVE HALF A CONSERVATORY ROOF.

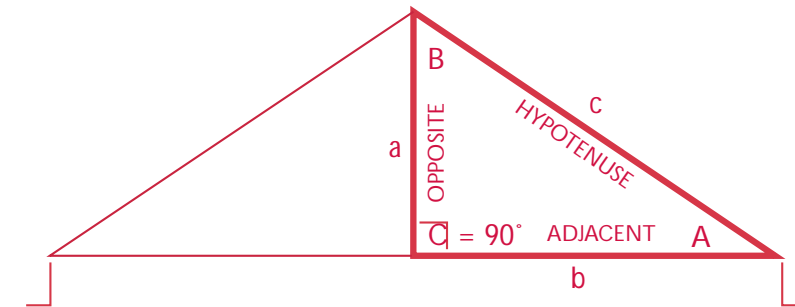

IF ONE ANGLE IS A RIGHT (90°) ANGLE, THE TRIANGLE IS A RIGHT OR RIGHT ANGLED TRIANGLE. THE SUM OF THE THREE ANGLES IN EVERY RIGHT ANGLED TRIANGLE IS 180 DEGREES.

THE SIDES OF THE TRIANGLE ARE KNOWN AS
 a = OPPOSITE b = ADJACENT c = HYPOTENUSE

A = THE PITCH OF THE ROOF

S SIN = SINE
 SOH
 $\sin A = \text{OPP} \div \text{HYP}$

C COS = COSINE
 CAH
 $\cos A = \text{ADJ} \div \text{HYP}$

T TAN = TANGENT
 TOA
 $\tan A = \text{OPP} \div \text{ADJ}$

COSEC = COSECANT
 $\text{COSEC } A = \text{HYP} \div \text{OPP}$

SEC = SECANT
 $\text{SEC } A = \text{HYP} \div \text{ADJ}$

COT = COTANGENT
 $\text{COT } A = \text{ADJ} \div \text{OPP}$

EXAMPLE

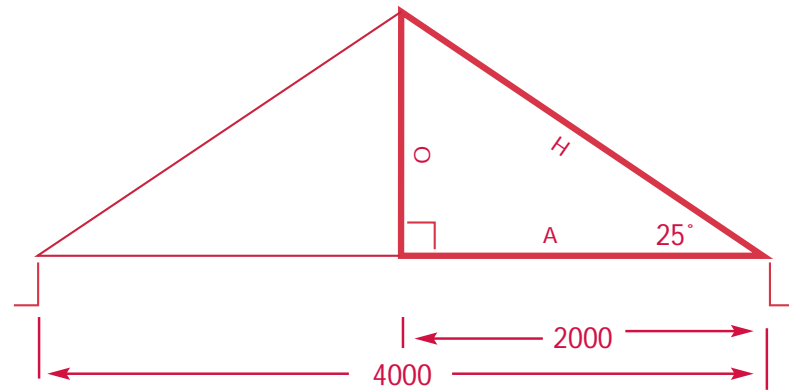

1. INTERNAL WIDTH OF CONSERVATORY = 4000MM
2. HALF INTERNAL WIDTH = 2000MM
3. KNOWN PITCH = 25°
4. HEIGHT OF TRIANGLE (OPPOSITE HEIGHT)

TO CALCULATE DIMENSION 'O'
 $\tan 25^\circ = \text{OPPOSITE} \div \text{ADJACENT}$
 $\therefore O = A \times \tan 25^\circ$
 $\therefore O = 2000 \times \tan 25^\circ$
 $\therefore O = 932.6\text{MM}$

IF ANGLE 25° IS NOT KNOWN BUT DIMENSION O IS KNOWN THEN
 $\tan X = O \div A$
 $\therefore \tan X = 932.6 \div 2000$
 $\therefore 932.6 \div 2000 = 0.4663^*$
 $\therefore \tan 0.4663 = 25^\circ$

PLEASE NOTE: THE ORDER IN WHICH DIGITS ARE PRESSED ON A SCIENTIFIC CALCULATOR CAN VARY DEPENDING ON MODEL.

*COTAN OR \tan^{-1} NEEDS TO BE OBTAINED FROM A SCIENTIFIC CALCULATOR.
 PROCESS : $932.6 \div 2000 = 0.4663$. NEXT PRESS SHIFT OR INV DIGIT. NEXT PRESS TAN DIGIT.
 NEXT PRESS = DIGIT.
ANSWER = 24.9996°

EXAMPLE

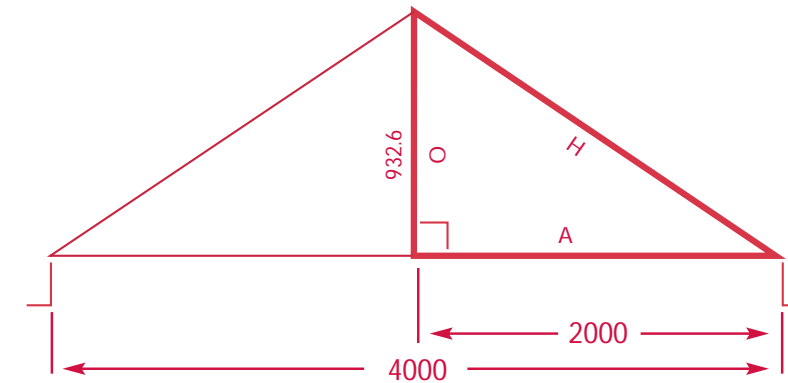

PYTHAGORAS THEOREM

THIS IS USED WHEN 2 SIDES ARE KNOWN IN A RIGHT ANGLED TRIANGLE AND YOU WANT TO KNOW THE THIRD

$$H^2 = O^2 + A^2$$

$$O^2 = H^2 - A^2$$

$$A^2 = H^2 - O^2$$

ON THE ABOVE EXAMPLE TO FIND LENGTH H
 $H^2 = O^2 + A^2$
 $H^2 = 932.6^2 + 2000^2 (932.6 \times 932.6 + 2000 \times 2000)$
 $H^2 = 869742.76 + 4000000$
 $H^2 = 4869742.76$
 $H = \sqrt{4869742.76}$ ($\sqrt{\quad}$ = SQUARE ROOT)
H = 2206.7

FIND DIMENSION X

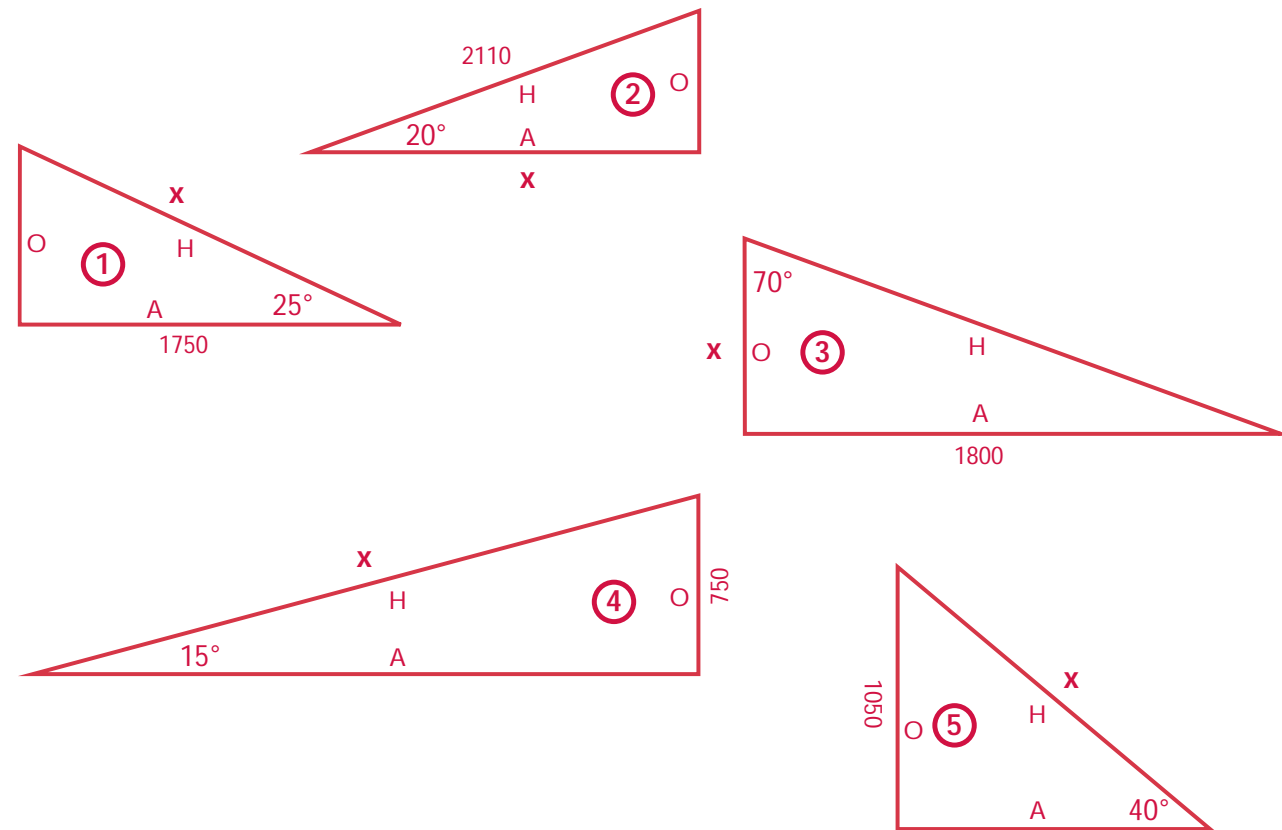

1. $\cos P = A \div H \therefore H = A \div \cos P \therefore H = 1750 \div \cos 25 \therefore H = 1931$
2. $\cos P = A \div H \therefore A = H \times \cos P \therefore A = 2110 \times \cos 20 \therefore A = 1983$
3. $\tan P = O \div A \therefore O = A \times \tan P \therefore O = 1800 \times \tan 20 \therefore O = 655$
4. $\sin P = O \div H \therefore H = O \div \sin P \therefore H = 750 \div \sin 15 \therefore H = 2898$
5. $\sin P = O \div H \therefore H = O \div \sin P \therefore H = 1050 \div \sin 40 \therefore H = 1633$

HOW TO CALCULATE

EQUAL INTERNAL ANGLES, FACET SIZES & BAY PROJECTIONS
ASSUMING EQUAL FACET SIZES WITH EQUAL INTERNAL ANGLES

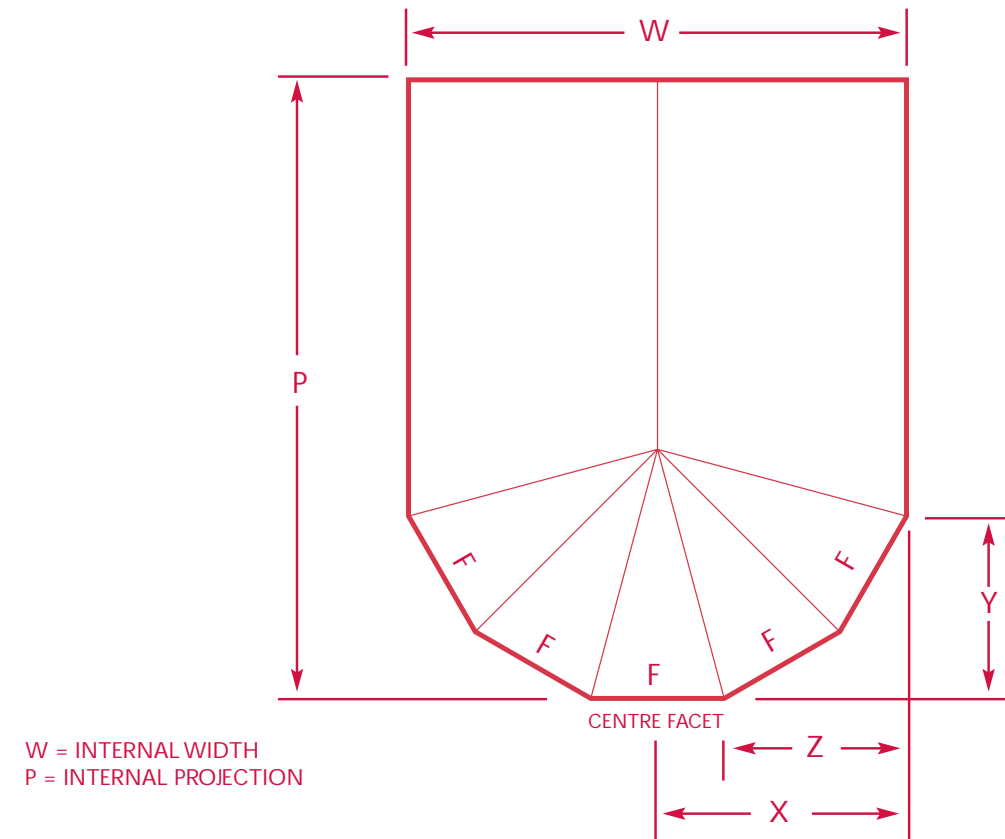

NOTE: IF ODD NO OF FACETS SELECTED (IE 5, 7 ETC) DIMENSION Y & Z ARE THE SAME.
IF EVEN NUMBER OF FACETS SELECTED (IE 6, 8 ETC) DIMENSION X ALWAYS HALF INTERNAL WIDTH. FOR DIMENSION Y, USE THE FORMULA ON PAGE 9.

HOW TO CALCULATE EQUAL INTERNAL ANGLES

FOR EACH ADDITIONAL FACET ADD 180° THEN DIVIDE BY THE NUMBER OF INTERNAL ANGLES

1 FACET = 180°	STRAIGHT LINE
2 FACETS = 360°	3 INTERNAL ANGLES @ 120.0°
3 FACETS = 540°	4 INTERNAL ANGLES @ 135.0°
4 FACETS = 720°	5 INTERNAL ANGLES @ 144.0°
5 FACETS = 900°	6 INTERNAL ANGLES @ 150.0°
6 FACETS = 1080°	7 INTERNAL ANGLES @ 154.3°
7 FACETS = 1260°	8 INTERNAL ANGLES @ 157.5°
8 FACETS = 1440°	9 INTERNAL ANGLES @ 160.0°
9 FACETS = 1620°	10 INTERNAL ANGLES @ 162.0°
10 FACETS = 1800°	11 INTERNAL ANGLES @ 163.6°
11 FACETS = 1980°	12 INTERNAL ANGLES @ 165.0°
12 FACETS = 2160°	13 INTERNAL ANGLES @ 166.2°
13 FACETS = 2340°	14 INTERNAL ANGLES @ 167.1°
14 FACETS = 2520°	15 INTERNAL ANGLES @ 168.0°

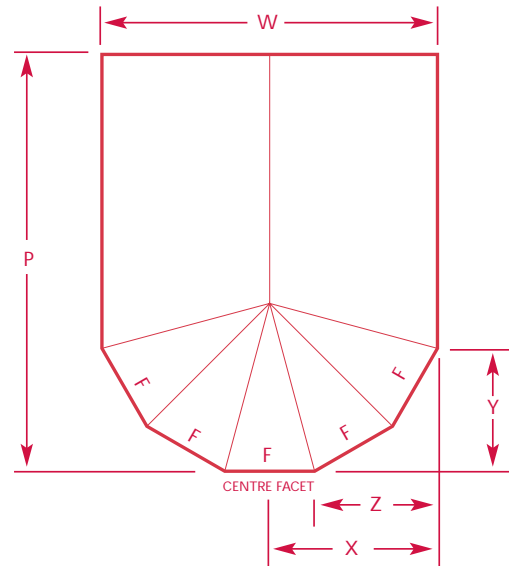

OR ALTERNATIVELY DIVIDE 180 BY THE NUMBER OF INTERNAL ANGLES AND SUBTRACT THE RESULT FROM 180, FOR EXAMPLE: 7 FACETS - 8 INTERNAL ANGLES

$$180 \div 8 = 22.5. \quad 180 - 22.5 = 157.5$$

HOW TO CALCULATE EQUAL FACET SIZES 'F'

THE FORMULA FOR EQUAL FACET SIZES IS:
180 DIVIDED BY THE NUMBER OF INTERNAL ANGLES =
DIVIDED BY 2 = TAN = x THE INTERNAL WIDTH

EXAMPLE: TO FIND THE FACET LENGTHS ON A 3 FACET VICTORIAN CONSERVATORY $180 \div 4 = 45 \div 2 = 22.5$. PRESS TAN = 0.4142 X THE INTERNAL WIDTH (EG. 3000MM) GIVES THE INTERNAL FACET SIZE OF 1242.6MM

2 FACETS	INTERNAL WIDTH x 0.5774
3 FACETS	INTERNAL WIDTH x 0.4142
4 FACETS	INTERNAL WIDTH x 0.3249
5 FACETS	INTERNAL WIDTH x 0.2679
6 FACETS	INTERNAL WIDTH x 0.2282
7 FACETS	INTERNAL WIDTH x 0.1989
8 FACETS	INTERNAL WIDTH x 0.1763
9 FACETS	INTERNAL WIDTH x 0.1584
10 FACETS	INTERNAL WIDTH x 0.1437
11 FACETS	INTERNAL WIDTH x 0.1316
12 FACETS	INTERNAL WIDTH x 0.1214
13 FACETS	INTERNAL WIDTH x 0.1127
14 FACETS	INTERNAL WIDTH x 0.1051

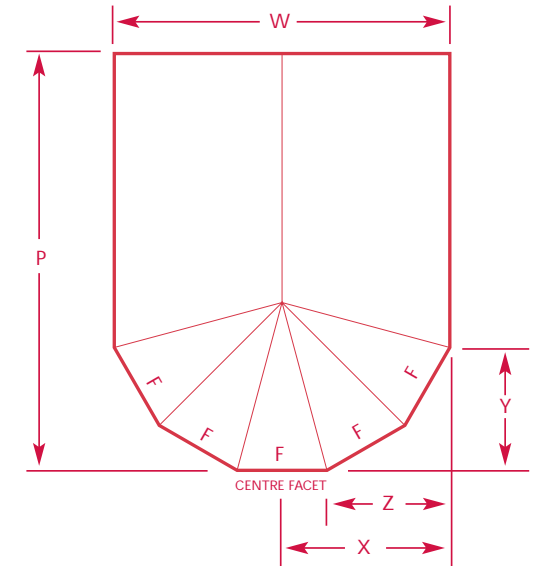

HOW TO CALCULATE

BAY PROJECTION - DIMENSION 'Y'

IF ODD NUMBER OF FACETS IS SELECTED (IE. 5, 7) THE BAY PROJECTION 'Y' AND DIMENSION 'Z' ARE THE SAME
 IF EVEN NUMBER OF FACETS SELECTED (IE. 6, 8) FOR BAY PROJECTION 'Y' USE THE FORMULA BELOW.

ODD FACETS: BAY PROJECTION 'Y' = INTERNAL WIDTH - CENTRE FACET ÷ 2

EVEN FACETS: BAY PROJECTION 'Y' =

2 FACETS	INTERNAL WIDTH x 0.2887
3 FACETS	INTERNAL WIDTH x 0.2929
4 FACETS	INTERNAL WIDTH x 0.3633
5 FACETS	INTERNAL WIDTH x 0.3660
6 FACETS	INTERNAL WIDTH x 0.3987
7 FACETS	INTERNAL WIDTH x 0.4005
8 FACETS	INTERNAL WIDTH x 0.4196
9 FACETS	INTERNAL WIDTH x 0.4208
10 FACETS	INTERNAL WIDTH x 0.4281
11 FACETS	INTERNAL WIDTH x 0.4342
12 FACETS	INTERNAL WIDTH x 0.4393
13 FACETS	INTERNAL WIDTH x 0.4436
14 FACETS	INTERNAL WIDTH x 0.4474

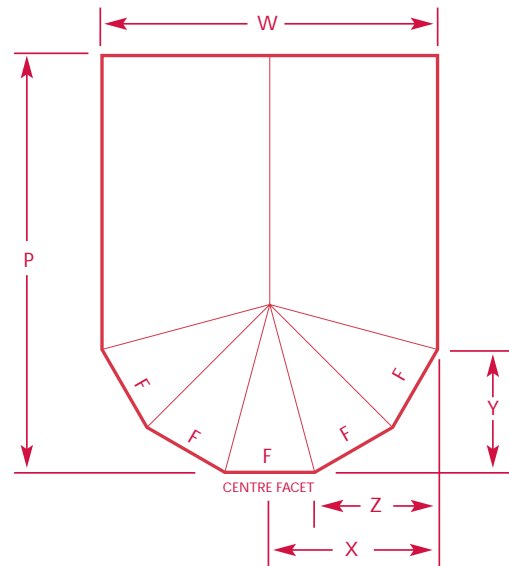

HOW TO CALCULATE

A LEAN-TO PITCH

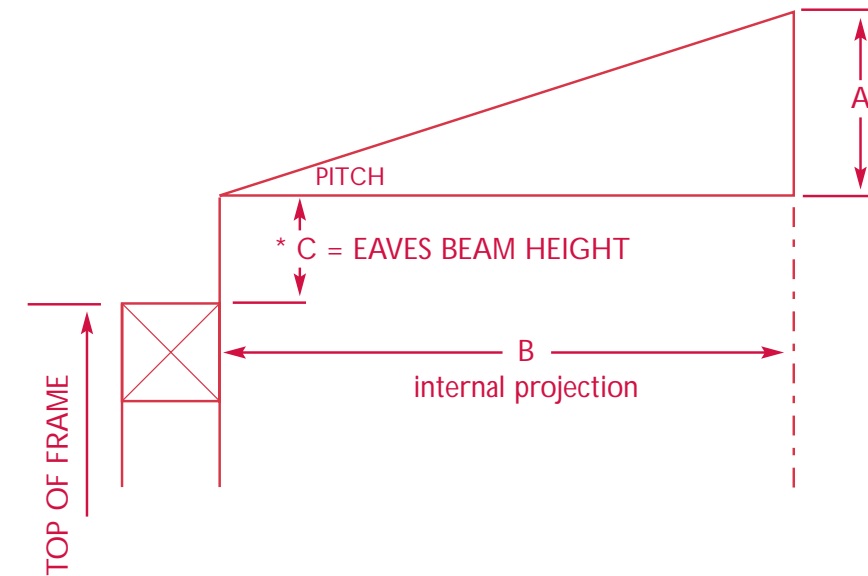

EXAMPLE: PROJECTION 3000MM - PITCH 10° (MULTI EAVES)

$$A = 3000 \times \tan 10^\circ = 528.9$$

$$A = 529\text{MM}$$

* C = EAVES HEIGHT

MULTI EAVES BEAM
 @ 5° AND 10° = 108MM
 @ 15°, 20° & 25° = 109MM
 @ 30° = 110MM

HOW TO CALCULATE

A LEAN-TO PITCH OFF A VICTORIAN PITCH
IE. ON P-SHAPE ROOF

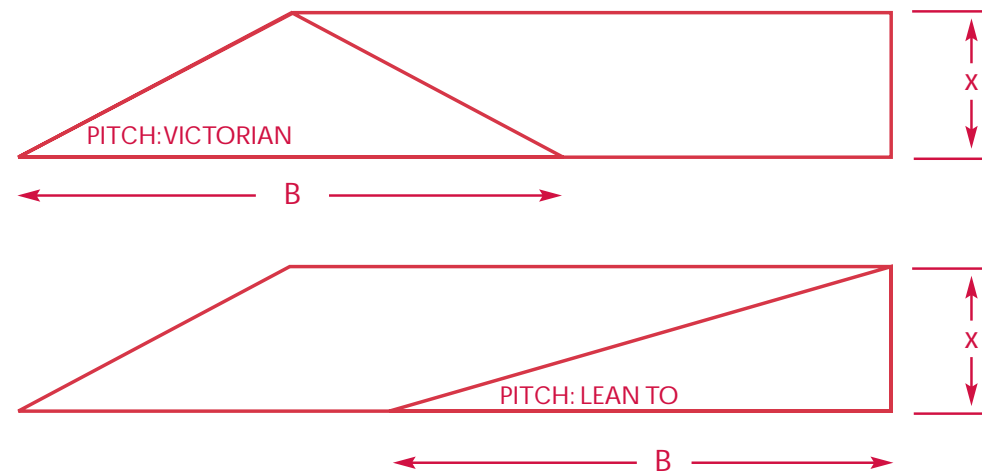

EXAMPLE: VICTORIAN WIDTH 3000MM
VICTORIAN PITCH 25°
LEAN-TO PROJECTION 2500MM
LEAN-TO PITCH ?

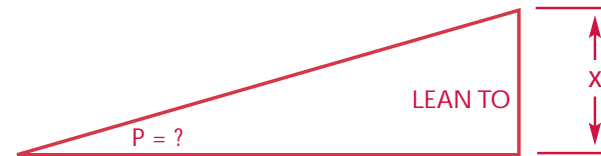

TO FIND THE HEIGHT OF ROOF DIMENSION X:
HALF VICTORIAN WIDTH = $1500 \times \tan 25^\circ = 699$

HEIGHT $699 \div$ PROJECTION $2500 = 0.2796$

PRESS: SHIFT OR INV (FOR \tan^{-1}) PRESS TAN (FOR \tan^{-1}) PRESS = 15°
PLEASE NOTE: THIS SEQUENCE VARIES DEPENDING UPON THE CALCULATOR USED.

1 UP 4 DOWN

MAIN RIDGE BODY RULES

THERE ARE SIX STANDARD MAIN MK4 RIDGE BODIES $15^\circ - 20^\circ - 25^\circ - 30^\circ - 35^\circ - 40^\circ$
EACH RIDGE BODY WILL ACCOMMODATE A 5° VARIATION IN PITCH. FOR EXAMPLE A 25°
WILL GO UP 1° TO 26° AND WILL GO DOWN 4° TO 21° . IF LOWER A 20° RIDGE BODY
WOULD GO UP TO 21° AND DOWN TO 16° .

THEREFORE: 15° RIDGE BODY - UP TO 15.9° - DOWN TO 15° **MINIMUM PITCH**

20° RIDGE BODY - UP TO 20.9° - DOWN TO 16°

25° RIDGE BODY - UP TO 25.9° - DOWN TO 21°

30° RIDGE BODY - UP TO 30.9° - DOWN TO 26°

35° RIDGE BODY - UP TO 35.9° - DOWN TO 31°

40° RIDGE BODY - UP TO 40.9° - DOWN TO 36°

RIDGES 41° AND ABOVE ARE FABRICATED FROM SHEET METAL AND ARE REFERRED TO AS MK1
RIDGES. RIDGES HAVE BEEN FABRICATED UP TO 55° , ALTHOUGH WE WOULD NOT
RECOMMEND RIDGES ABOVE 50° .

TAPERING EAVES BEAM OR BOX GUTTER

3 FACET VIC WITH TAPERING EAVES

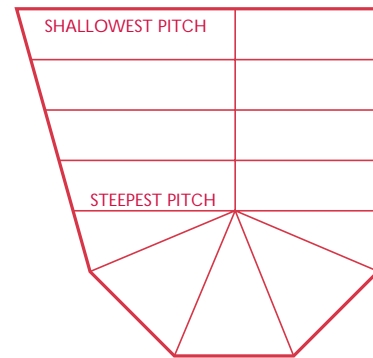

ALL GLAZING BARS ON THE LEFT SIDE OF THE ROOF ARE IN TWIST. CAN BE GLAZED IN POLYCARBONATE - **NOT GLASS**

3 FACET VIC WITH TAPERING BOX GUTTER

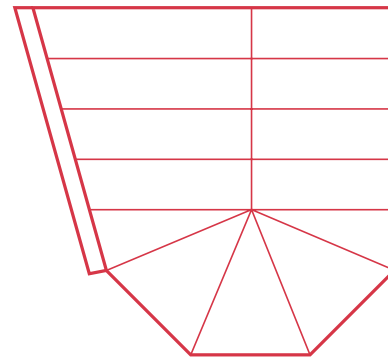

GLAZING BARS LAY FLAT ON THE RIDGE BODY - THEN TWISTED TO LAY FLAT ON THE EAVES BEAM.

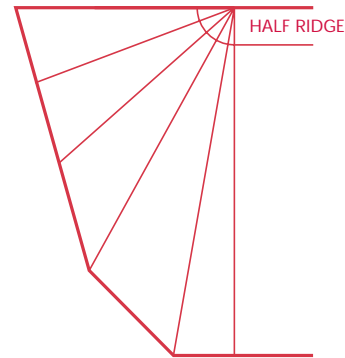

A PREFORMED SHEET METAL FABRICATED END IS SHAPED TO MINIMISE THE TWIST IN THE GLAZING BARS TO EAVES BEAM LOCATION.

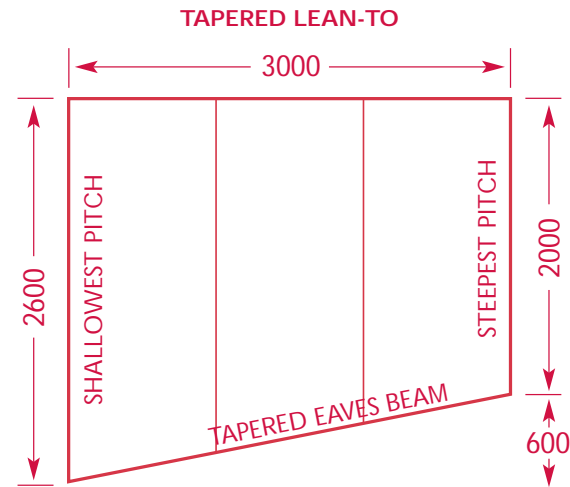

PLEASE NOTE: THE MAXIMUM TAPER IS 200MM PER 1000MM

NB. TAKE CARE NOT TO EXCEED THE 1 UP 4 DOWN RULE EG. IF USING A 25MM RIDGE BODY AND THE SHALLOWEST PITCH IS 21° BUT THE STEEPEST PITCH EXCEEDS 26° THE DESIGN MUST BE ALTERED IE. A FABRICATED RIDGE WILL BE REQUIRED.

HOW TO CALCULATE

A DROP VALLEY PITCH

ALSO KNOWN AS A LOWERED VALLEY

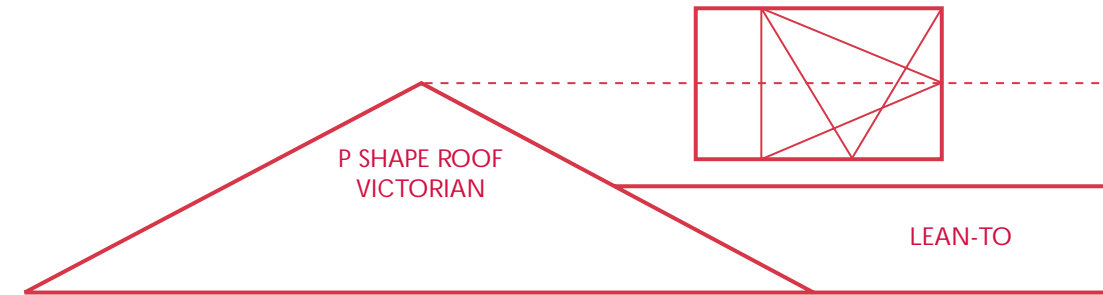

USUAL REASON FOR A LOWERED VALLEY IS A HEIGHT RESTRICTION AS ILLUSTRATED ABOVE

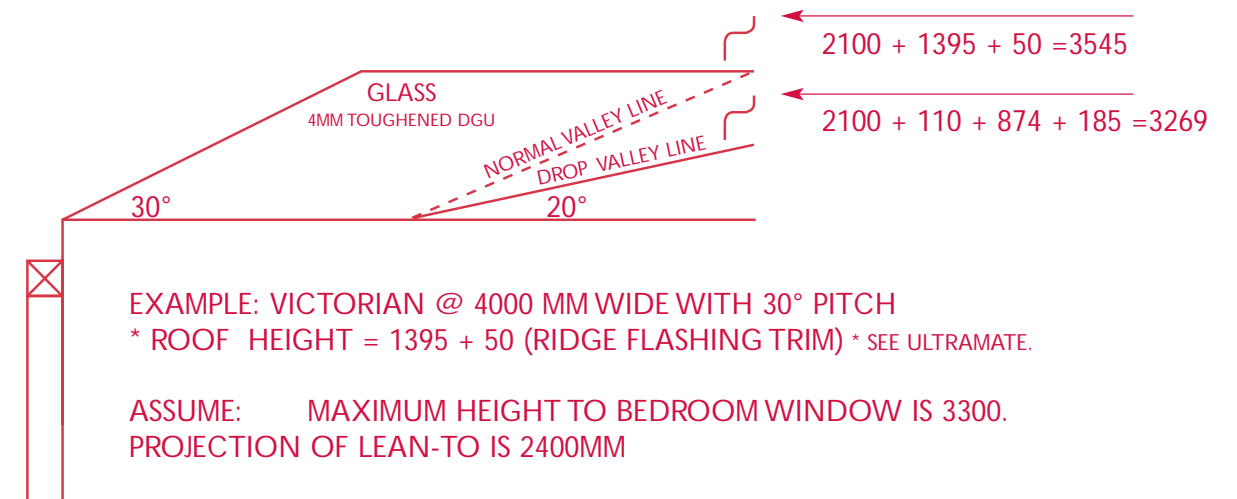

FRAME HEIGHT	=	2100
EAVES HEIGHT	=	110 (MULTI EAVES BEAM)
2400 X TAN 20° HEIGHT	=	874
**SERIES 7 BAR HEIGHT	=	185 (TOP OF HALF RIDGE UPSTAND)
OVERALL HEIGHT	=	3269

** SEE FABRICATION GUIDE PAGE 19 (HALF RIDGE) OR SURVEYORS GUIDE PAGE 16
 PLEASE NOTE: INSTALLATION LOCATION IS IMPORTANT: PLEASE REFER TO THE STRUCTURAL DESIGN GUIDE

HOW TO CALCULATE P SHAPE HALF RIDGE LENGTH WITH HIPPED END

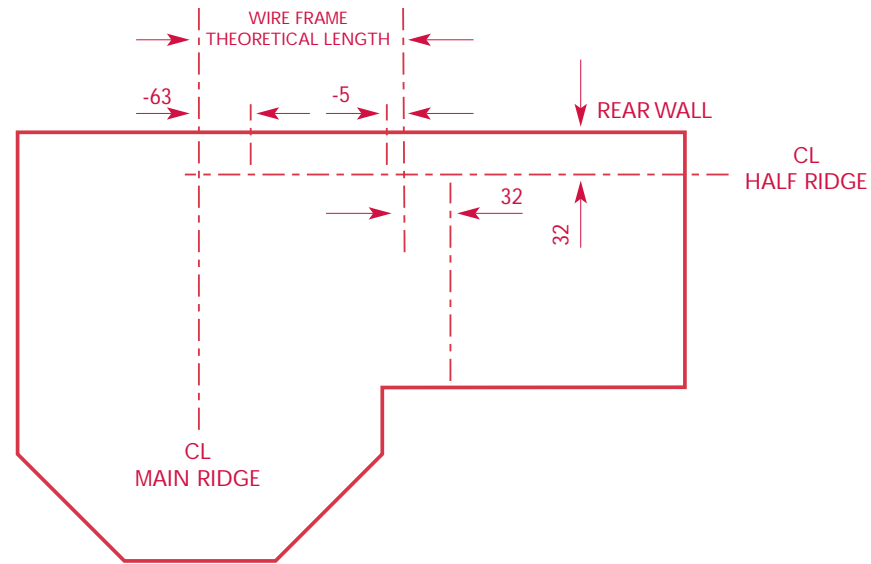

- 63 CENTRE LINE OF MAIN RIDGE TO START OF HALF RIDGE (MK4)
- 5 HALF RIDGE REDUCTION TO ACCOMMODATE 5MM ADAPTOR PLATE

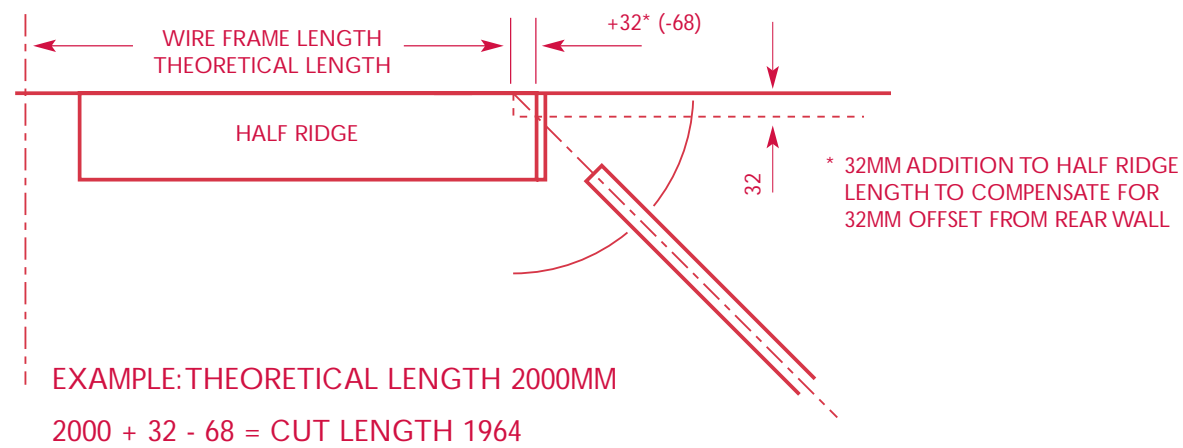

HOW TO CALCULATE WIRE FRAME GLAZING BAR LENGTHS

- * ACTUAL GLAZING BAR LENGTH WILL BE DETERMINED BY:
- A. REDUCTION FROM FINIAL POINT TO START OF BAR
- B. OVERHANG FROM INTERNAL FRAME

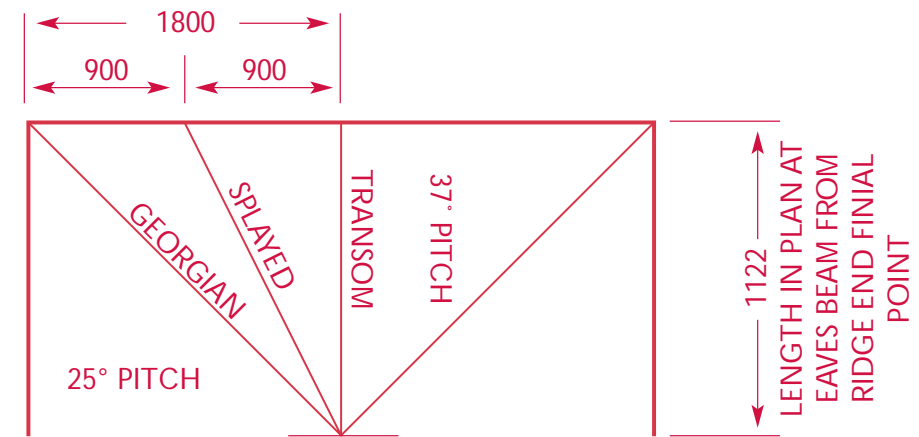

VICTORIAN HIP OR SPLAYED

$$1122 \div \cos 37^\circ = 1404.89$$

$$\text{PRESS } X^2 \text{ PRESS} = (1973733.357) + 900 \text{ (FROM CENTRE LINE TO SPLIT)}$$

$$\text{PRESS } X^2 \text{ (SQUARED)}$$

$$\text{PRESS} = (2783733.357)$$

$$\text{PRESS } \sqrt{\text{(SQUARE ROOT)}}$$

$$\text{PRESS} = 1668.45$$

GEORGIAN HIP

$$1122 \div \cos 37^\circ = 1404.89$$

$$\text{PRESS } X^2 \text{ PRESS} = (1973733.357) + 1800 \text{ (HALF INTERNAL WIDTH)}$$

$$\text{PRESS } X^2 \text{ (SQUARED)}$$

$$\text{PRESS} = (5213733.357)$$

$$\text{PRESS } \sqrt{\text{(SQUARE ROOT)}}$$

$$\text{PRESS} = 2283.36$$

TRANSOM BAR

$$1122 \div \cos 37^\circ = 1404.89$$

HOW TO CALCULATE VENTILATED WALL PLATE HEIGHTS

MINIMUM PITCH 5° TO MAXIMUM PITCH 30°

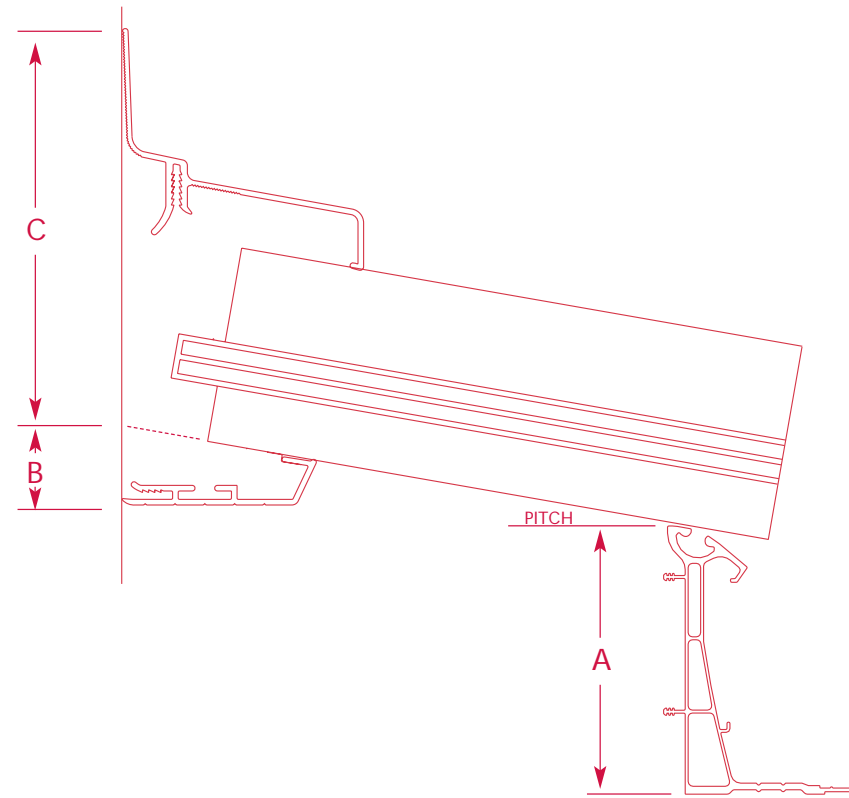

DIM A

- 5° - 109MM
- 10° - 109MM
- 15° - 109MM
- 20° - 109MM
- 25° - 110MM
- 30° - 111MM

DIM B

- 5° - 25MM
- 10° - 32MM
- 15° - 35MM
- 20° - 41MM
- 25° - 47MM
- 30° - 54MM

DIM C

BAR TYPE	CAPA	
	SERIES 7	CHAMBERED SERIES 7
5°	163MM	168MM
10°	156MM	161MM
15°	151MM	156MM
20°	148MM	153MM
25°	145MM	150MM
30°	140MM	145MM

EXAMPLE: PROJECTION 3000MM - PITCH 20° - POLY - FRONT FRAME 2100MM
 $3000 \times \tan 20^\circ = 1091.91$ 7 SERIES BAR
 FULL HEIGHT = $2100 + 109 + 1092 + 148 = 3449$
 HEIGHT TO UNDERCLADDING = $2100 + 109 + 1092 - 41 = 3260$

HOW TO CALCULATE PWP & PWL WALLPLATE HEIGHTS

MINIMUM PITCH 5° TO MAXIMUM PITCH 35°

PWL - FIXED ANGLE WALLPLATE 5° - 10°

PWP - VARIABLE ANGLE WALLPLATE 15° - 35°

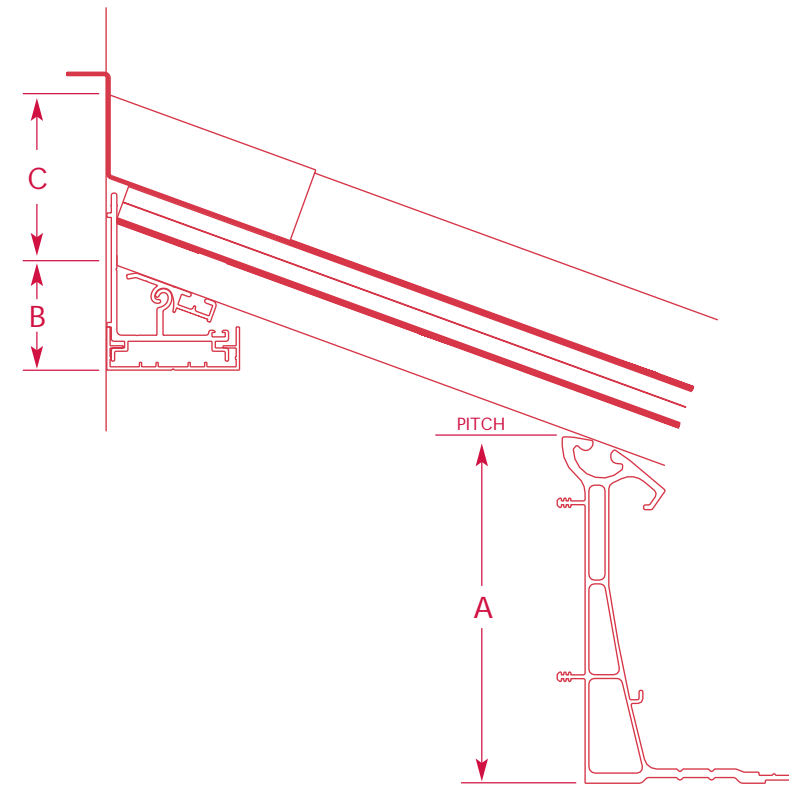

DIM A

- 5° - 109MM
- 10° - 109MM
- 15° - 109MM
- 20° - 109MM
- 25° - 110MM
- 30° - 111MM
- 35° - 112MM

DIM B

- 5° - 26MM
- 10° - 30MM
- 15° - 46MM
- 20° - 48MM
- 25° - 51MM
- 30° - 54MM
- 35° - 58MM

DIM C

BAR TYPE	CAPA	
	SERIES 7	CHAMBERED SERIES 7
5°	79MM	84
10°	79MM	84
15°	81MM	86
20°	83MM	88
25°	86MM	91
30°	91MM	96
35°	95MM	100

EXAMPLE: PROJECTION 3000MM - PITCH 20° - POLY - FRONT FRAME 2100MM
 $3000 \times \tan 20^\circ = 1091.91$ 7+ SERIES BAR
 FULL HEIGHT = $2100 + 109 + 1092 + 83 = 3384$
 HEIGHT TO UNDERCLADDING = $2100 + 109 + 1092 - 48 = 3253$

HOW TO CALCULATE RIDGE LENGTHS

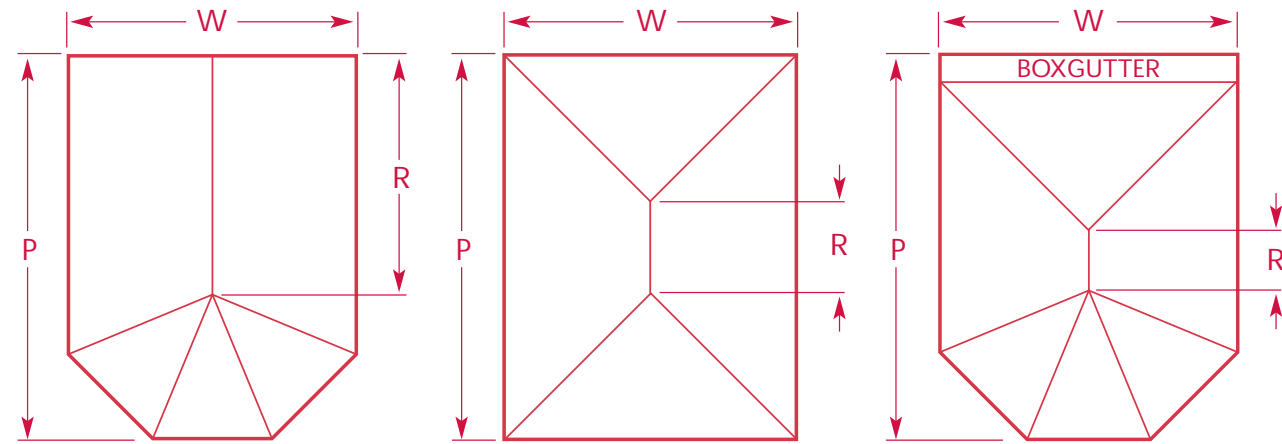

SINGLE ENDED RIDGE
 $R = P - \frac{1}{2} \text{ WIDTH}$
 EXAMPLE: $P = 4000$ $W = 4000$
 THEREFORE $R = 4000 - 2000$
 RIDGE LENGTH = 2000MM

DOUBLE ENDED RIDGE
 $R = P - W$ (IF P IS GREATER THAN W) NOTE: IF W IS GREATER THAN P, THE RIDGE WOULD RUN PARALLEL TO W
 EXAMPLE: $P = 5000$ $W = 4000$
 THEREFORE $R = 5000 - 4000$
 RIDGE LENGTH = 1000MM

DOUBLE ENDED RIDGE WITH BOXGUTTER
 $R = P - \text{BOXGUTTER WIDTH} - \text{WIDTH}$
 EXAMPLE: $P = 5165$, $W = 4000$.
 THEREFORE $P - \text{BOXGUTTER WIDTH} = 5165 - 165 = 5000$
 RIDGE = 5000 - 4000
 RIDGE LENGTH = 1000MM

HOW TO CALCULATE PITCH AND HEIGHT OF A CONSERVATORY WHEN GIVEN AN EXACT HEIGHT RESTRICTION

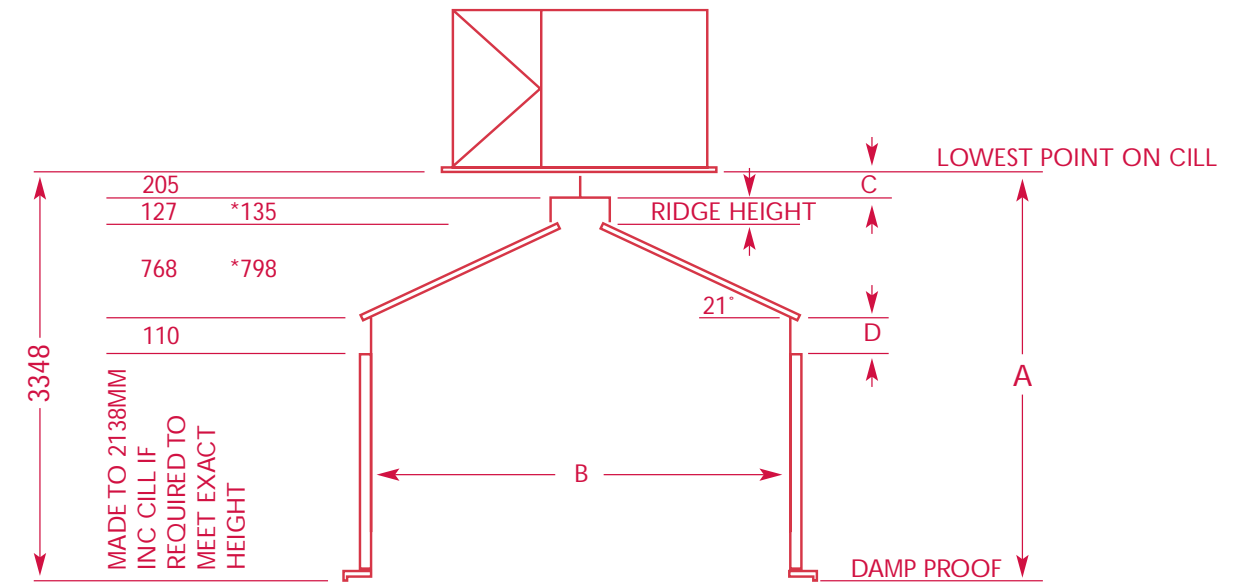

DIMENSION A: GIVEN DIMENSION 3348 FROM BEDROOM CILL TO DPC
DIMENSION B: GIVEN DIMENSION 4000MM INTERNAL WIDTH
GLAZING MATERIAL: POLYCARBONATE
GLAZING BAR: SERIES 7
DIMENSION C: CRESTING SELECTED: CLASSIC = 205MM
DIMENSION D: MULTI EAVES BEAM HEIGHT = 110MM

3348 HEIGHT RESTRICTION
 2100 INDUSTRY STANDARD FRAME HEIGHT
 110 EAVES BEAM HEIGHT
 205 CLASSIC CRESTING HEIGHT
 149* MAX HEIGHT OF RIDGE FOR 7 SERIES BAR
 $\therefore 3348 - 2100 - 110 - 205 - 149 = 784$
 $\div 2000$ (HALF INT. WIDTH) = 0.392
 PRESS SHIFT OR INV - PRESS TAN (FOR TAN⁻¹) = 21.40°

*ASSUMED MAX DIMENSION 149MM
 SERIES 7 BAR @ 15°
 ACTUAL DIMENSION @ PITCH OF 21.40° WOULD BE 141MM
 THEREFORE 784 WOULD REDUCE TO 776MM
 $\therefore 776 \div 2000 = 0.388$ PRESS SHIFT
 THEN TAN = 21.20°
 EXACT PITCH = 21.20°
 PRACTICAL PITCH = 21°
 (2000 X TAN 21° = 768MM)
 SEE DIAGRAM FOR EXACT HEIGHTS

NOTE: DIMENSIONS BASED ON SERIES 7 BAR WITH STD CAPAS
 ADD ADDITIONAL 5MM FOR CHAMBERED CAPPINGS

HOW TO CALCULATE

EXTERNAL BASE & INTERNAL FRAME SIZES -
WHEN COMING OFF A WALL

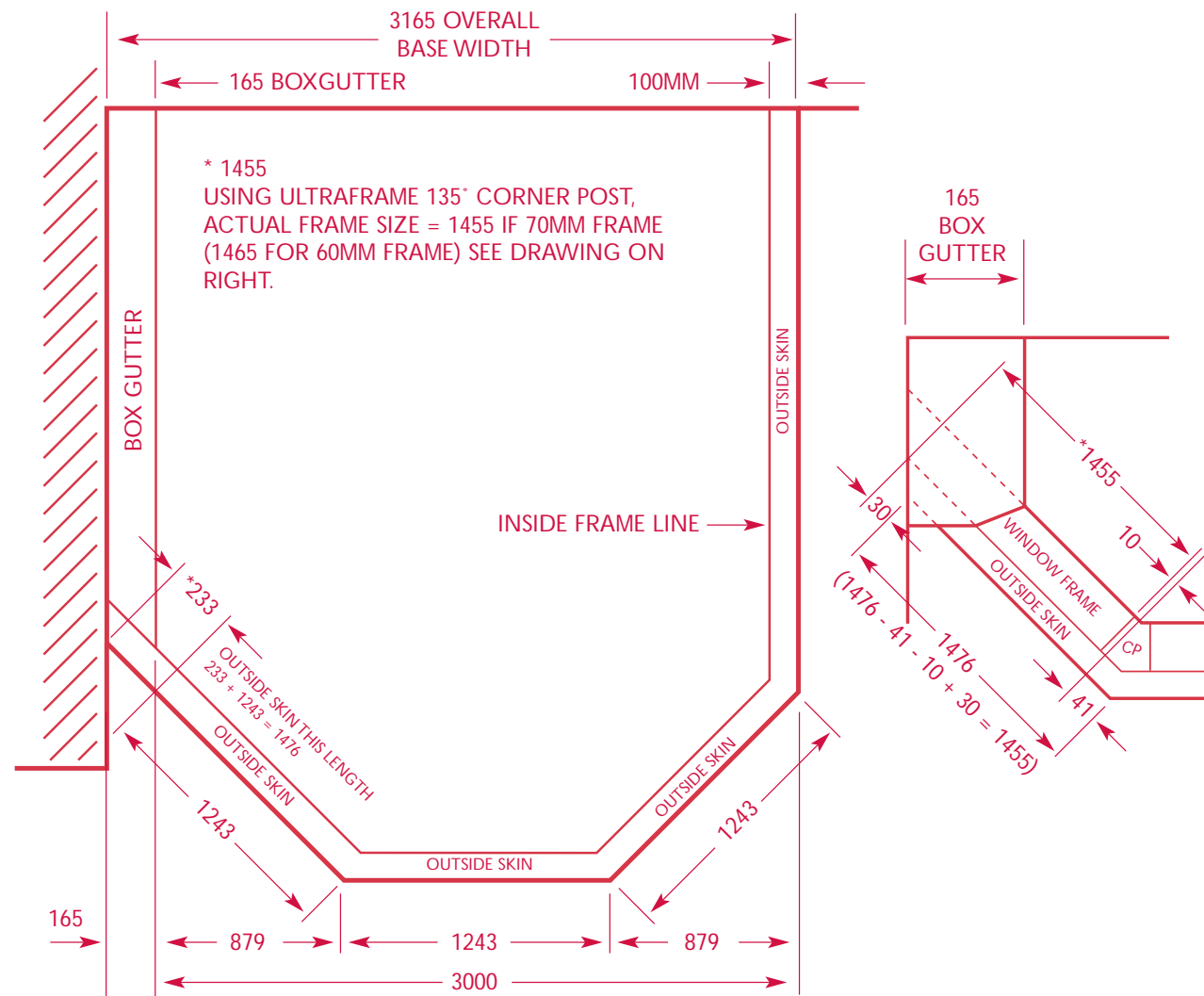

* 233 CALCULATED FROM $165 \div \cos 45 = 233$

HOW TO CALCULATE

TOTAL HEIGHT OF ROOF ABOVE EAVES FOR
LEAD FLASHING RUN

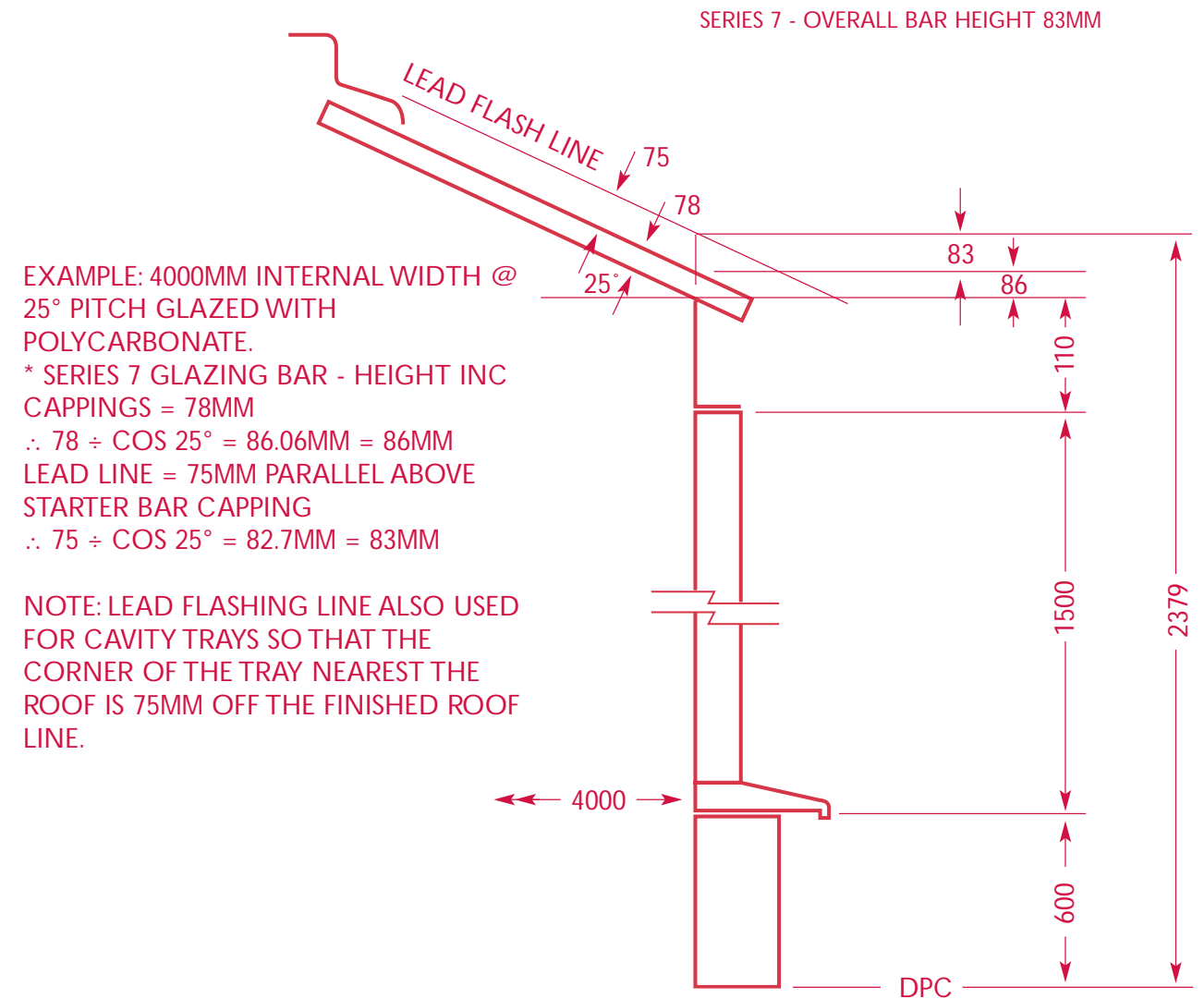

NOTE: DIMENSIONS BASED ON
SERIES 7 BAR WITH STD CAPAS
ADD ADDITIONAL 5MM FOR
CHAMBERED CAPPINGS

HOW TO CALCULATE

THE ROOF SIZE (PROJECTION) IF FITTING A BOXGUTTER TO A BUNGALOW FASCIA

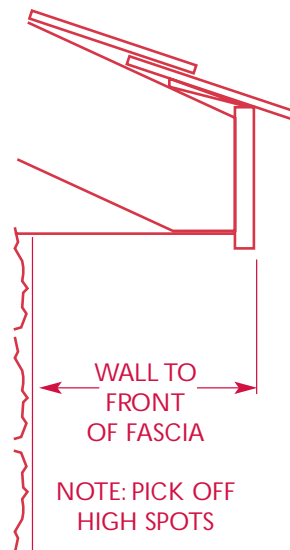
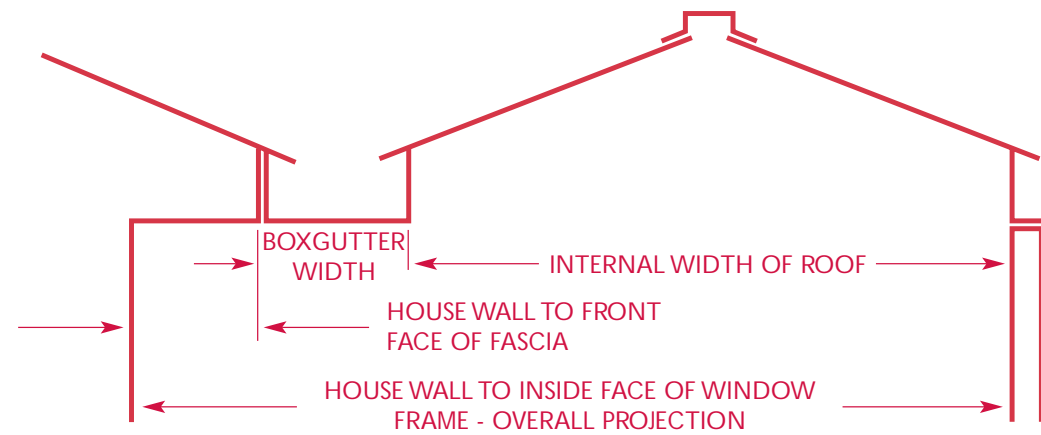

EXAMPLE: OVERALL PROJECTION 4000MM
 WALL TO FRONT OF FASCIA 235MM
 BOXGUTTER WIDTH 265MM
 ACTUAL INTERNAL ROOF DIMENSION =
 $4000 - (235 + 265) = 3500\text{MM}$

ROOF SIZE = 3500MM

HOW TO CALCULATE

A DOOR OPENING ON A BRICKWORK 3 AND 5 FACET USING THE ULTRAFRAME CORNERPOST SYSTEM

