

portal structure

frame specification

Frame Specification

Stanchions	195 x 80mm	Main portal frame	6082 T6 Aluminium
Rafters	195 x 80mm	Main portal frame	6082 T6 Aluminium
Hips	195 x 80mm	Main portal hip	6082 T6 Aluminium
Eaves beam	145 x 100mm	Main portal eaves	6082 T6 Aluminium
Purlins	125 x 50mm	Main portal purlin	6082 T6 Aluminium
Base plate	300 x 300 x 10mm thick		5083 Grade 0 Aluminium
Splice plate	Specially extruded structural aluminium, keyed, to interlock internally within the main portal frame, secured with M16 countersunk stainless steel bolts.		
Holding down bolts	M12 Rawlplug expanding safetyplus hex-nut anchor		
Connection bolts	M16 stainless steel bolts		

Finishes

The standard finish of the structural grade aluminium used for the portal frame is a specialist applied polyester powder coating. Standard finishes are Standard white (RAL 9010 satin), Deeplas white (BS00E55), Brown (RAL 8017 matt) or Light Oak (RAL 8003 matt). Alternatively you can specify any BS or RAL colour.

Roofing System

The roof system consists of a ridge beam member and glazing bar sections extruded from Aluminium to BS1474: 1987, Material designation - T6, glazed with multi-walled polycarbonate panels or double glazed sealed units. The units are of varying thicknesses, 16, 20, 24 and 28mm, and kite marked to BS5713:1979.

The glazing bar with PVCu internal and external claddings and the TPE co-extruded gaskets are attached to the eaves beam, ridge beam and purlin members with zinc plated steel bolts (captive in slots in the ridge and eaves beam aluminium extrusions) and to the portal rafter members at regular intervals. The hip bars are secured to the hip portal rafters and to the formed aluminium wok at the ridge point.

The glazing panels or units, supported by the glazing bars, are located into the ridge system through a PVCu rain baffle and co-extruded gasket providing a seal against ingress of moisture. External PVCu caps with TPE co-extruded gaskets snap into position on the glazing bars and hold down the roof panels or units, forming a seal between the internal and external gaskets.

An opening roof vent, either manual or electric, can be incorporated into the glazing system.

A PVCu gutter system is attached to the aluminium eaves beam with face fix brackets.

Box gutters

Profile to suit extruded/fabricated aluminium box gutters.

Materials

Aluminium roofing components	Grade 6063 T6 to BS8118
Aluminium portal components	Grade 6082 T6 to BS8118

British Standards (applied to portal design)

BS648: 1964	Schedule of weights of building materials
BS5516: 1991	Design and installation of vertical and sloping patent glazing
BS6262: 1982	Glazing for buildings
BS6399: part 1 - 1984	Code of practice for dead and imposed loads
BS6399: part 2 - 1997	Loading for building codes of practice for wind loads
BS6399: part 3 - 1998	Loading for building codes of practice for imposed roof loads
BS8118: part 1 - 1991	Structural use of Aluminium Part 1 codes of practice for design
BS8118: part 2 - 1991	Structural use of Aluminium Part 2 spec for materials, works and procedures

portal structures

what makes up a portal?

Portal Stanchions & Portal Rafter

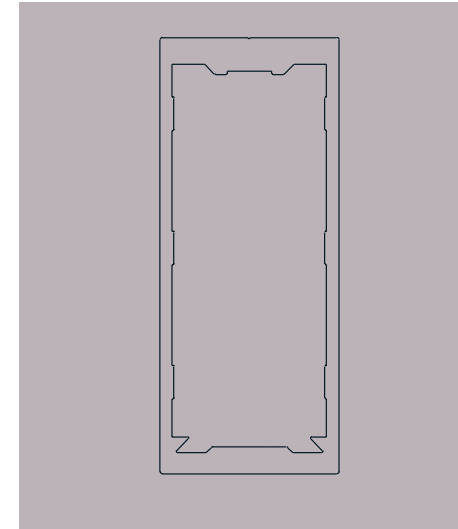

Splice Section

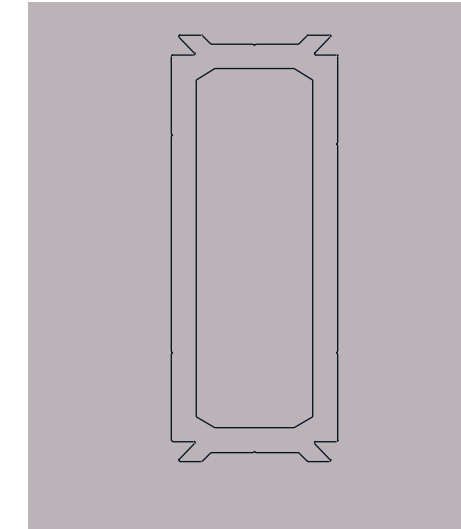

Eaves Beam

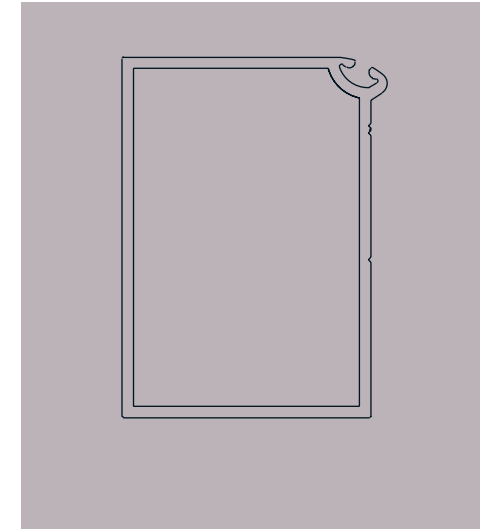

Purlin Shoe

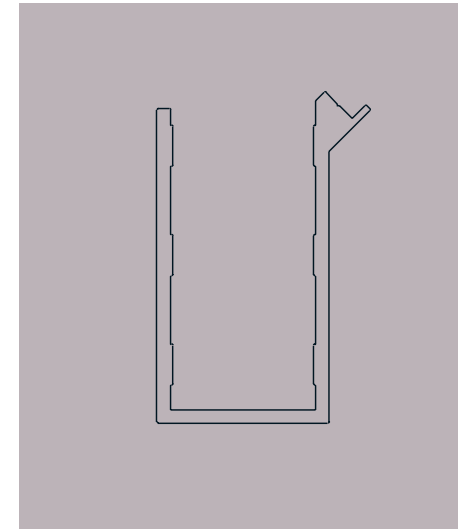

Parabolic Purlin

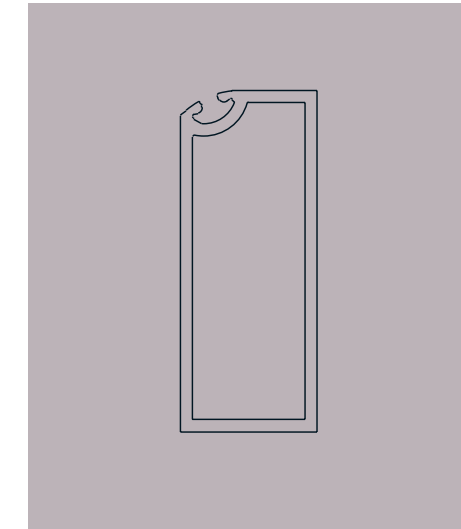

Window Clip

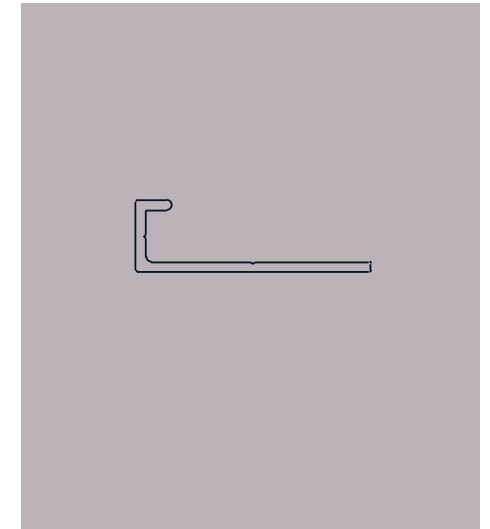

Hip Rafter

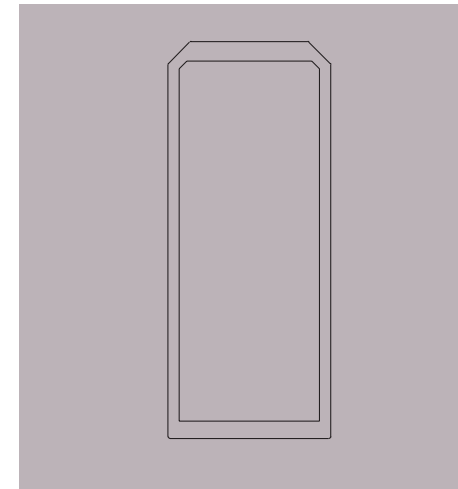

Apex Hip Connector

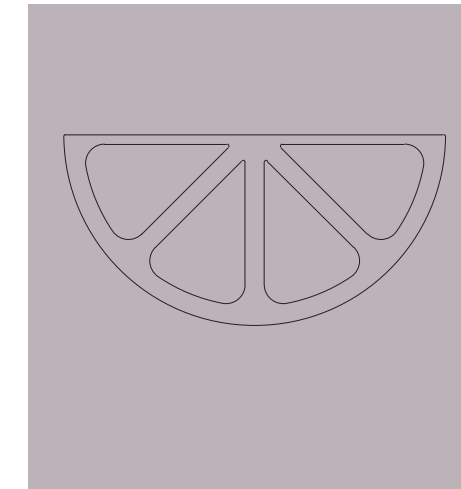

Hip 'T' Fin

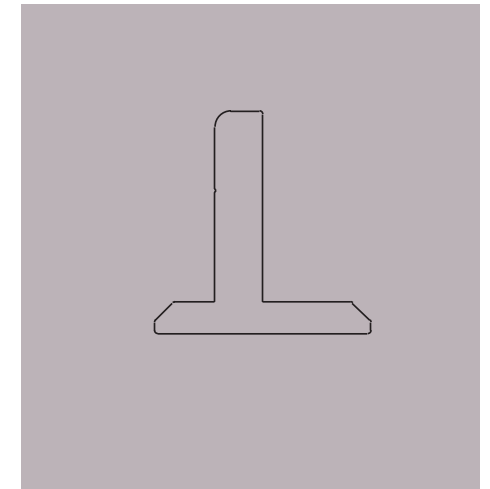

typical details of a portal structure

The portal frame comprises stanchions, rafters, eaves beams and purlins and when bolted together forms the skeletal framework that provides lateral stability to the conservatory structure as a whole. The roof components and window frames form the external envelope to the conservatory.

The following details show typical set-out arrangements for reference purposes only.

Should you require a particular detail please contact the portals team on 01200 452340 or email portals@ultraframe.co.uk.

The portal skeleton, indicating location of details

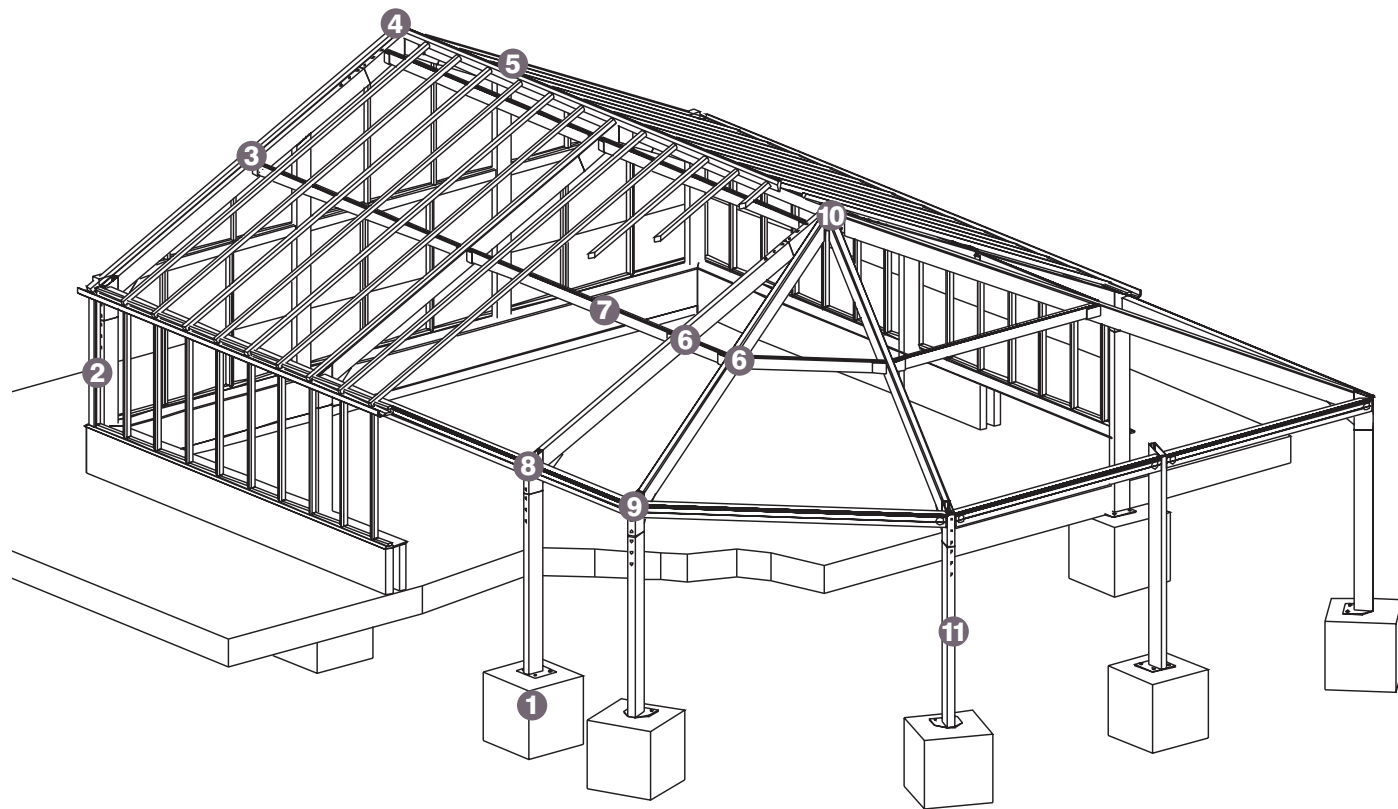

- Key:**
- 1 Base plates
 - 2 Portal leg/window frame arrangements
 - 3 Gable fascia detail
 - 4 Gable end profile
 - 5 Section through ridge
 - 6 Shoe arrangements
 - 7 Roof purlins
 - 8 Eaves detail
 - 9 Splice connection
 - 10 Hip connections
 - 11 Vertical section

1. BASE PLATES

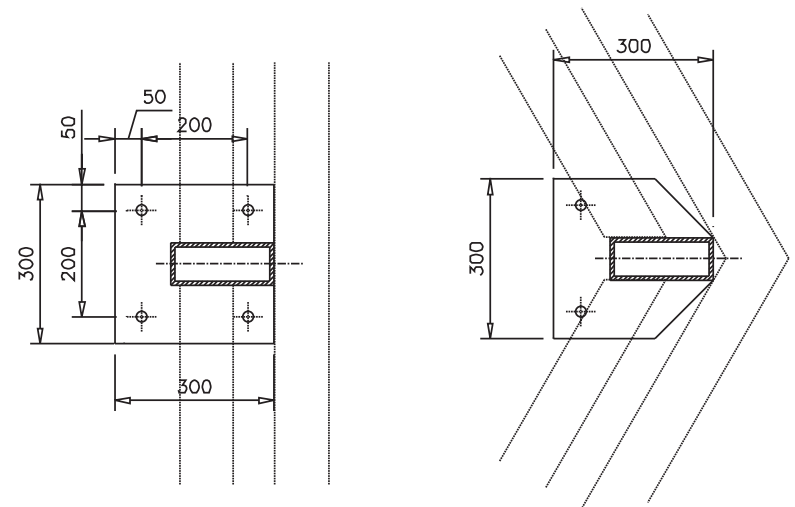

2. PORTAL LEG/WINDOW FRAME ARRANGEMENTS

Note, for illustrative purposes only, all frames are shown externally beaded

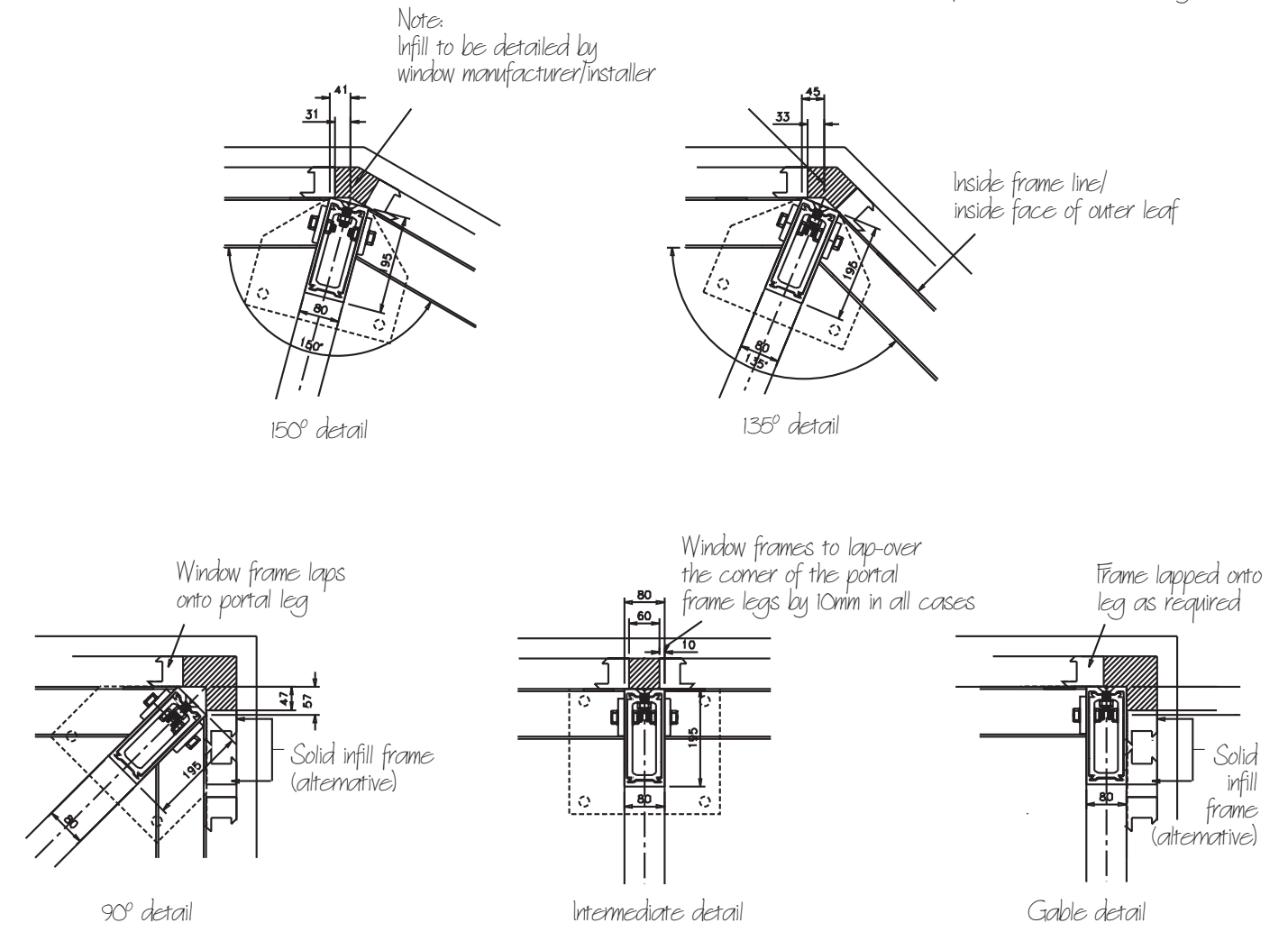

3. GABLE FASCIA DETAIL

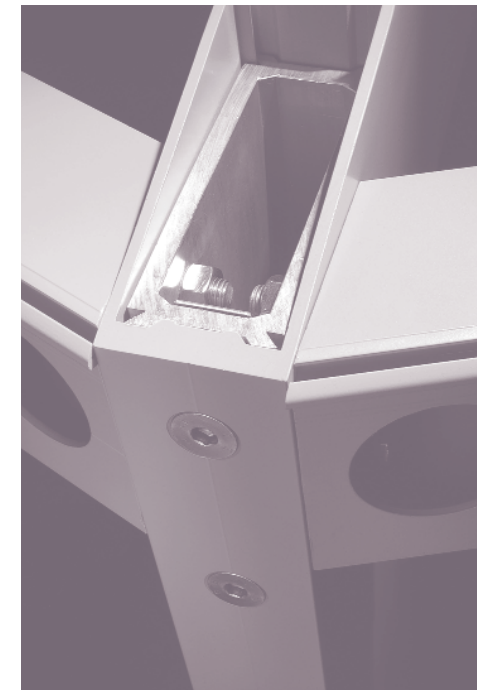
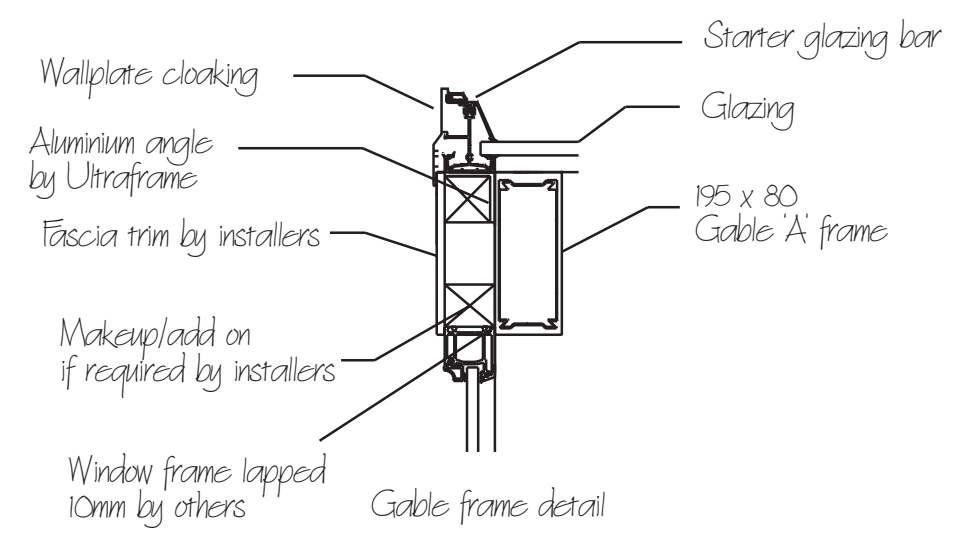

4. GABLE END PROFILE

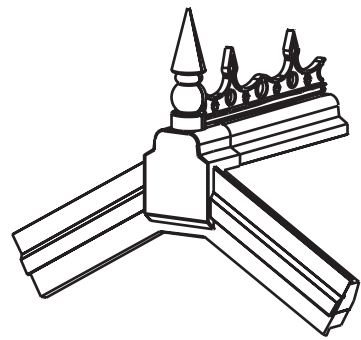

Typical end view on gable

5. SECTION THROUGH RIDGE

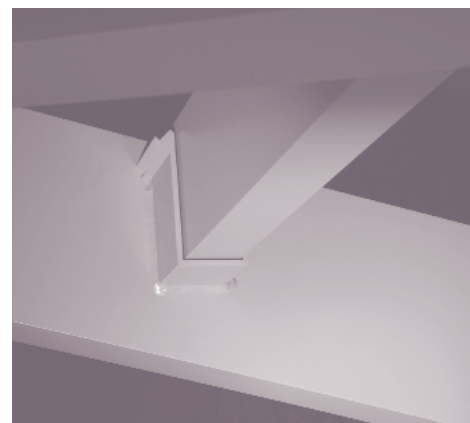
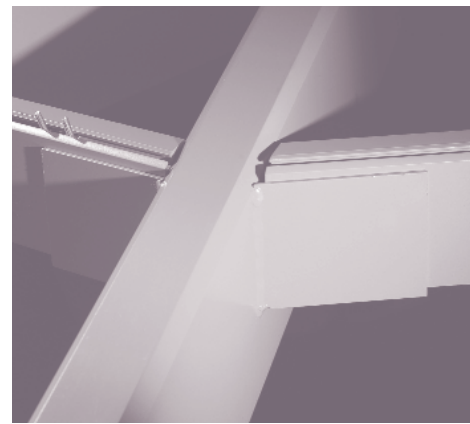
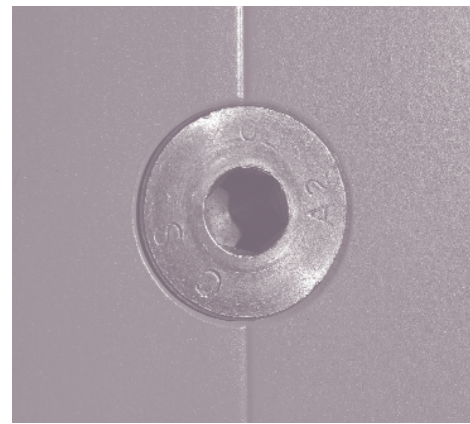
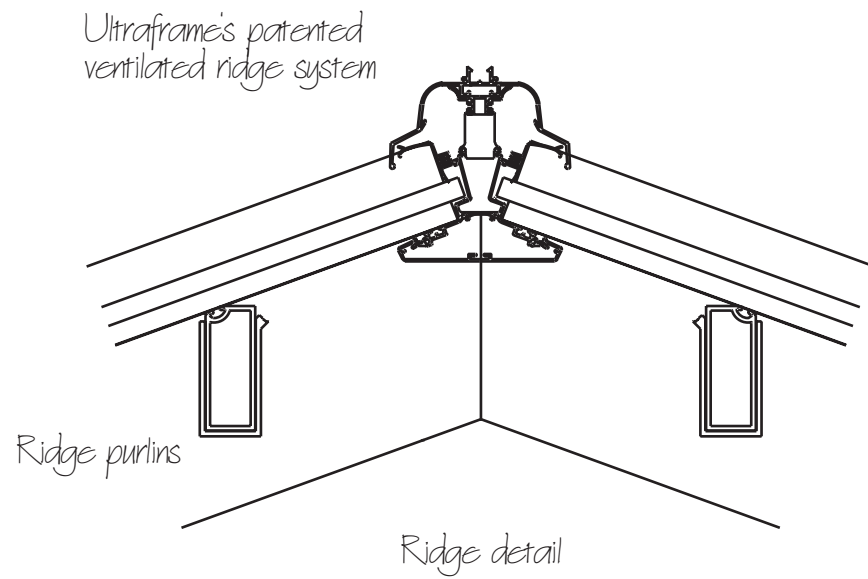

6. SHOE ARRANGEMENTS

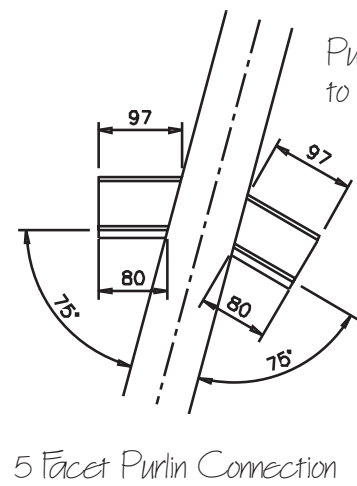
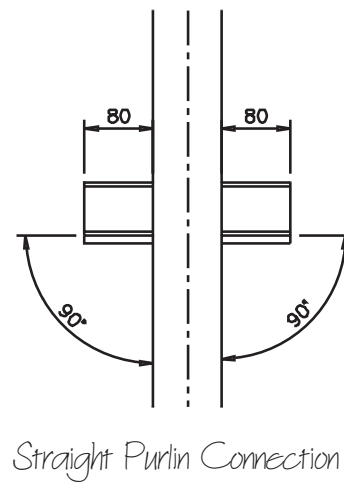
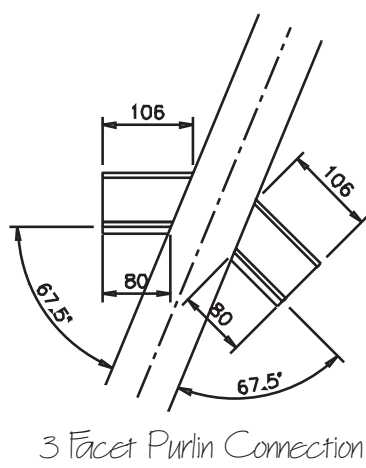

Purlin shoes welded to rafters

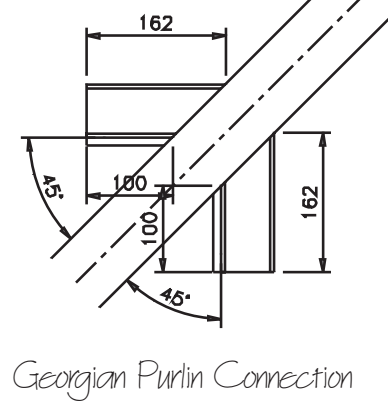

7. ROOF PURLINS



3 number Tek-Screws required to fix purlin shoes to purlins supplied by Ultraframe



Section through purlin shoe



8. EAVES DETAIL

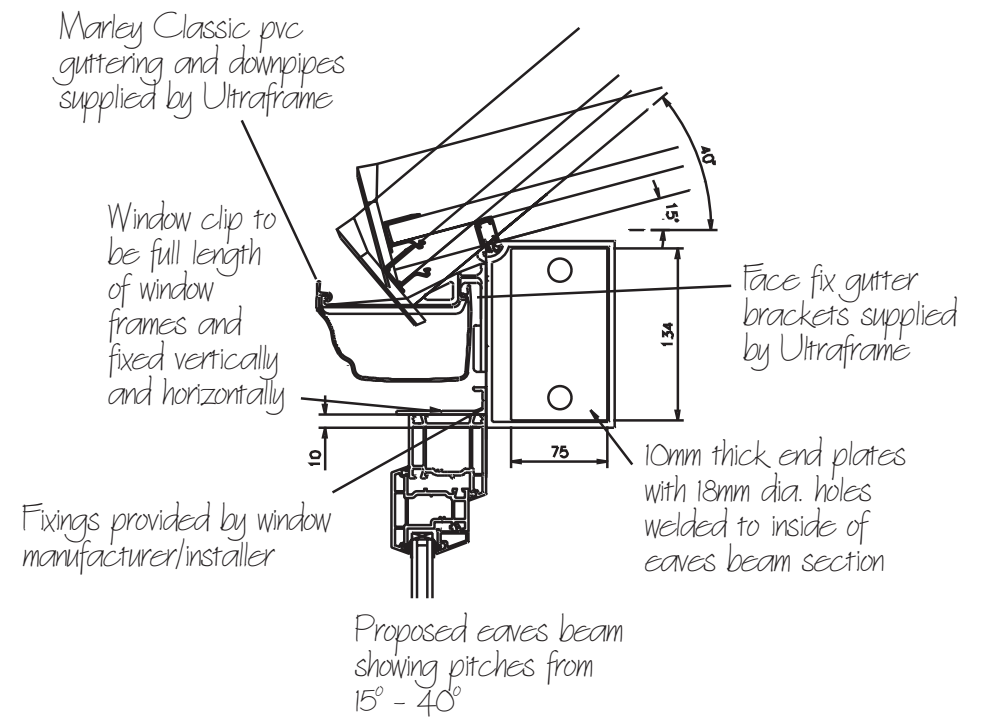

Fixings provided by window manufacturer/installer

9. SPLICE CONNECTION

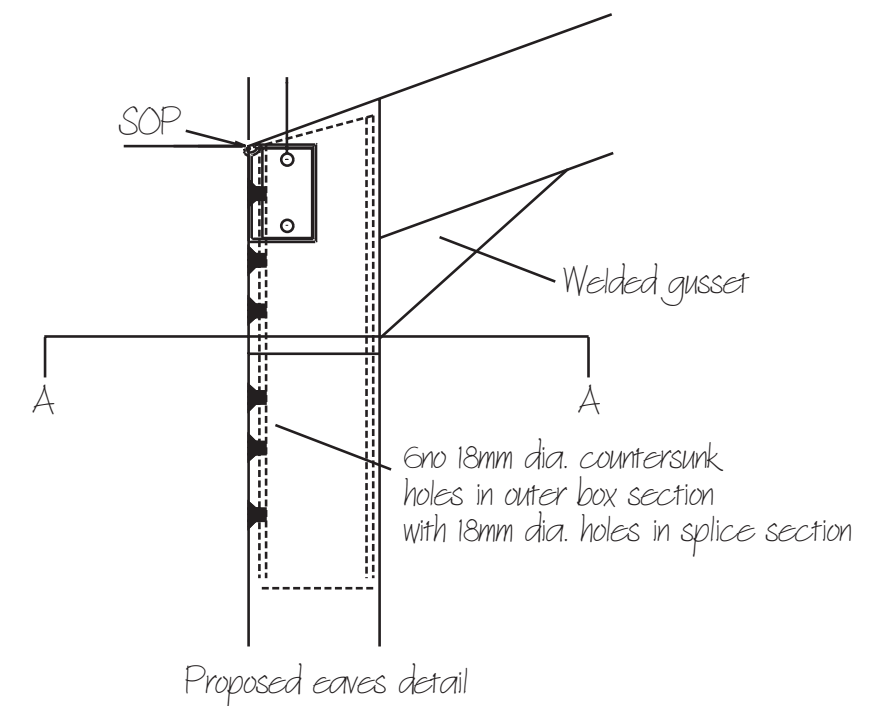

Section A-A

10. HIP CONNECTORS

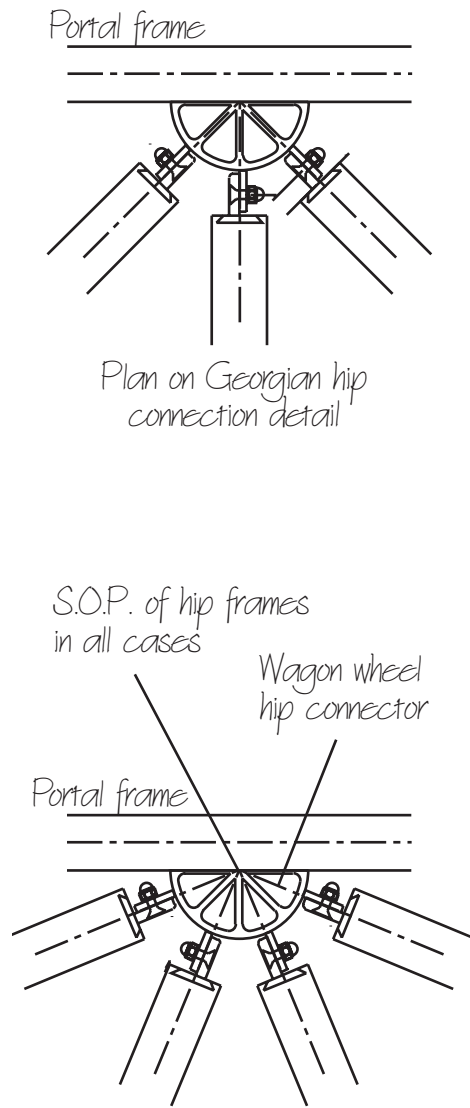

Plan on 3 facet hip connection detail

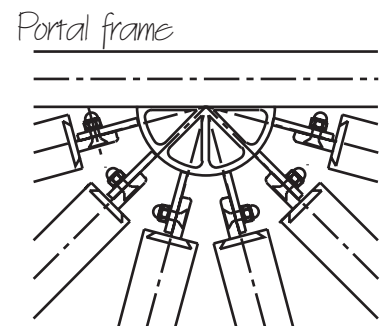

Plan on 5 facet hip connection detail

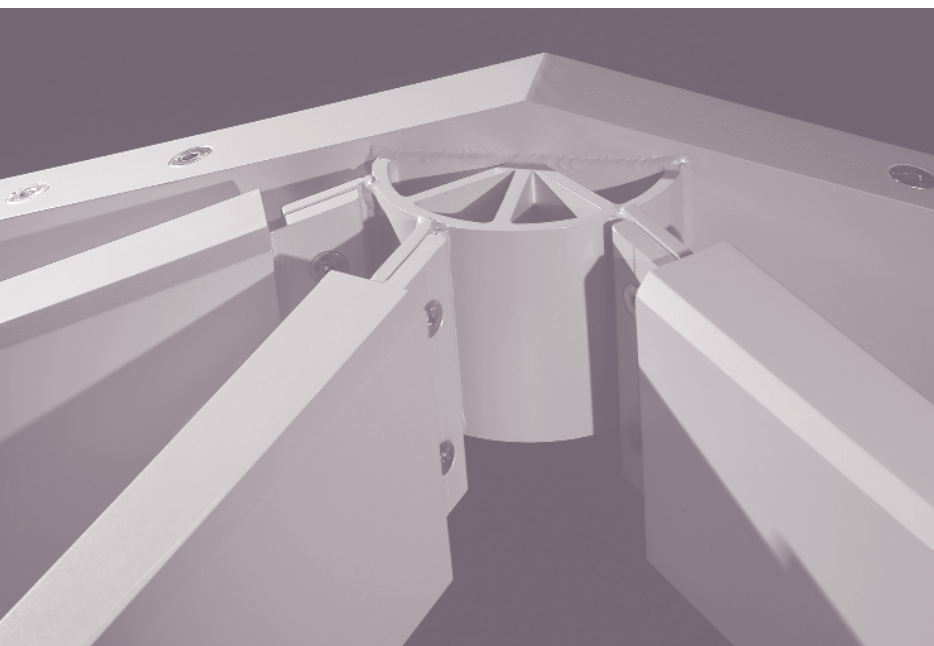

11. VERTICAL SECTION

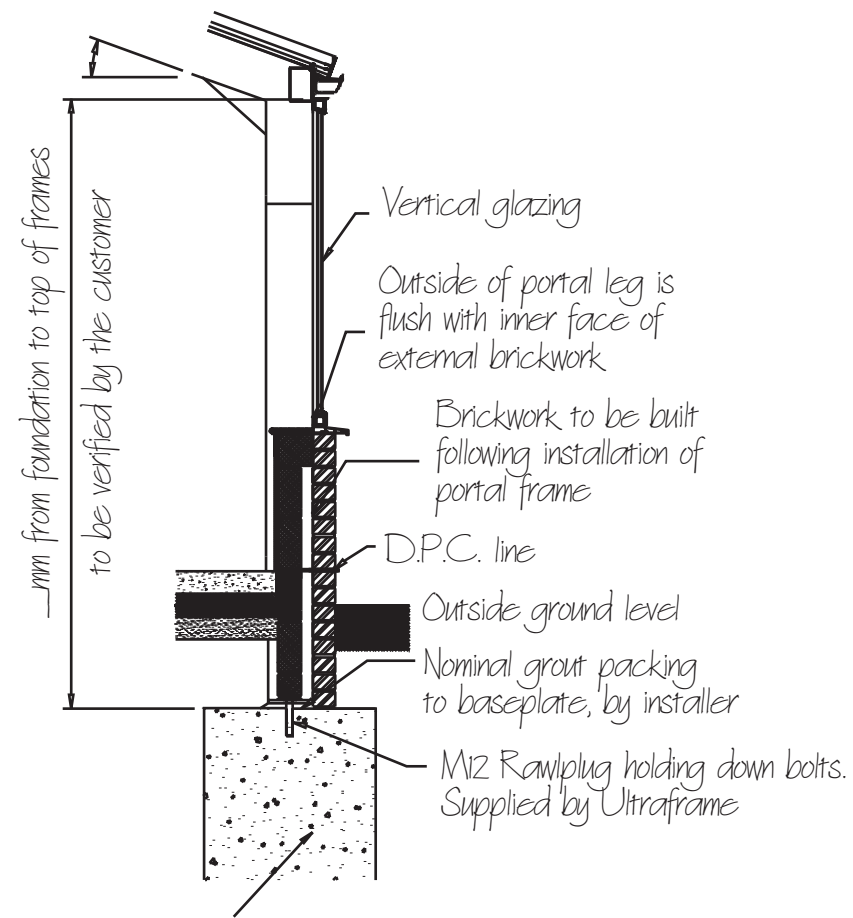

Foundation size, specification and type by suitable qualified engineer. Design dependent upon frame reactions supplied by Ultraframe and ground conditions investigated by client's engineer

portal extras

TYPICAL LANTERN DETAILS

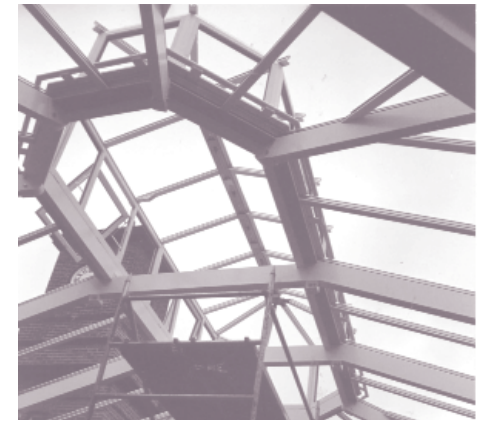
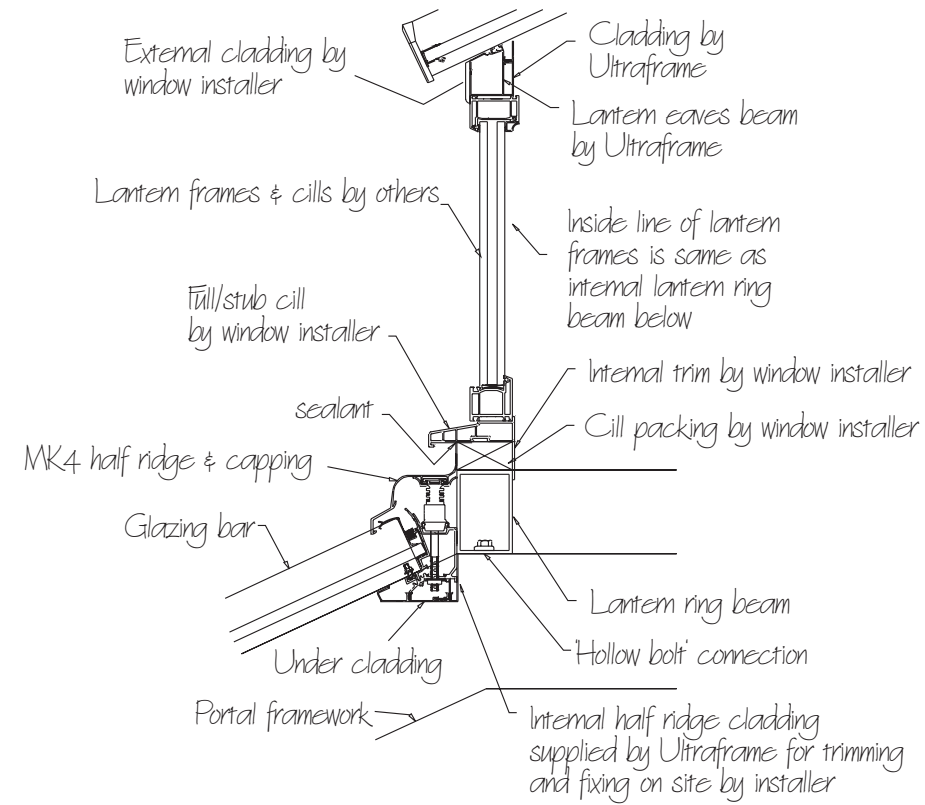

TYPICAL BOX GUTTER DETAILS

Fabricated Box Gutter

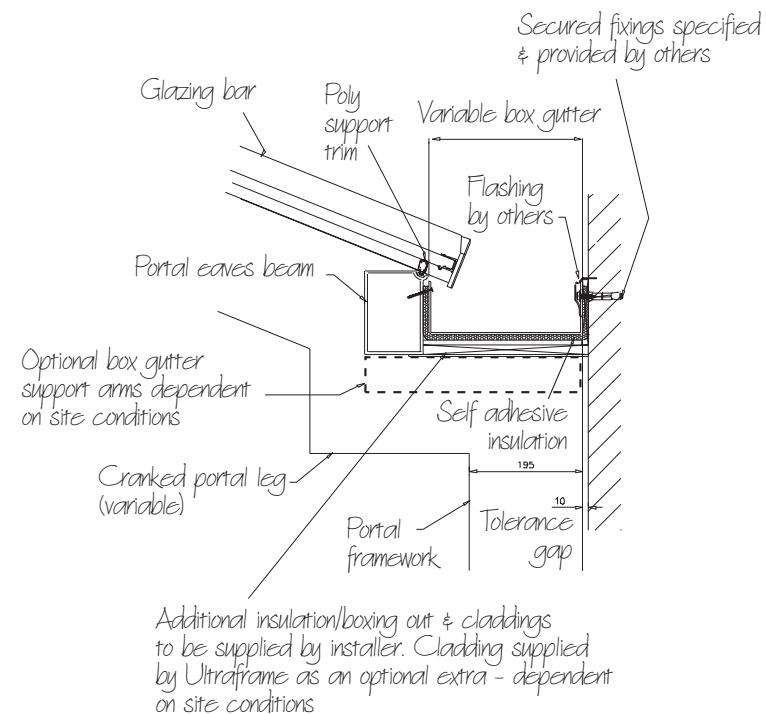

Extruded Box Gutter

